

2 INTERPRETATION, LAND USE SPECIFIC REGULATIONS & SITE DESIGN STANDARDS PART 2A

2A.1 PURPOSE OF CHAPTER

- (1) The purpose of this Chapter is to:
 - (a) define words, terms and phrases which are necessary for the understanding, administration and enforcement of this Bylaw, and which are not part of common English usage;
 - (b) provide regulations and performance standards that apply to specific land uses, which are permitted or discretionary within the various land use zones of this Bylaw; and
 - (c) provide regulations that apply to any land use or development on any site, irrespective of the land use zone in which it is located.
- (2) Word, phrases and terms which are not defined in this Chapter shall be given their usual and customary meaning except where the context clearly indicates a different meaning.

(#2022-30, s. 15, 2022)

PART 2B DEFINITIONS

– A –

The following words, terms and phrases, wherever they occur in this Bylaw, shall have the meanings assigned to them by this Part.

“**abut,**” means either:

- (a) touching or sharing a common point, line or boundary; or
- (b) separated from any common point, line, or boundary measured from the two closest points on the property by only:
 - (i) an existing or planned lane;
 - (ii) an existing or planned easement less than 9 metres in width;
 - (iii) an undeveloped lot or portion of a lot less than 9 metres in width;
 - (iv) an existing or planned road right-of-way less than 9 metres in width.

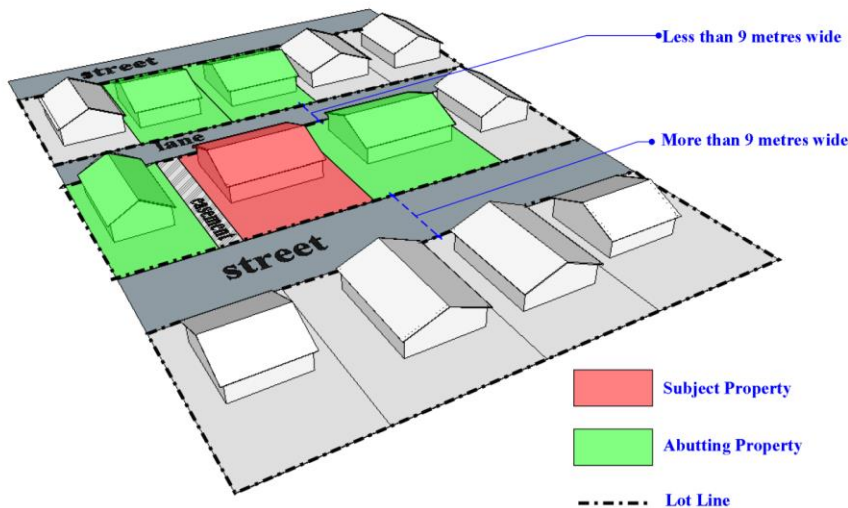

Figure 2B.F1: Abut

“**accessory**” means a separate building or structure, normally incidental, subordinate, exclusively devoted to and located on the same lot as the principal building or structure.

“**active use**” includes the following land uses and or any land use in the listed land use classes:

- (a) Assembly, Community;
- (b) Dwelling, Unit;
- (c) Food & Beverage land use class;

- (d) Industry land use class;
- (e) Institution, Day Care;
- (f) Industry, Laboratory;
- (g) Office land use classes;
- (h) Public Use land use class;
- (i) Retail Trade, Shop;
- (j) Retail Trade, Outdoor Display; and
- (k) Service Trade land use class;

“**active wall**” means the exterior walls of a building, at street level, that animates the public realm through the incorporation of glazing, fenestration, and regular entrances.

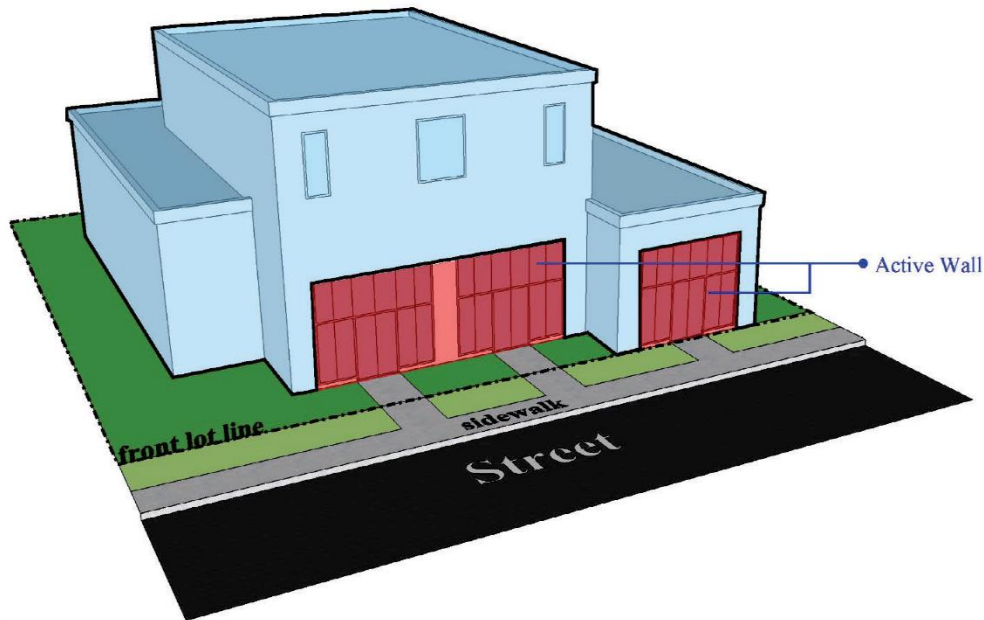

Figure 2B.F2 – Active Wall

“**adjoin**” means touching or sharing a common line or boundary.

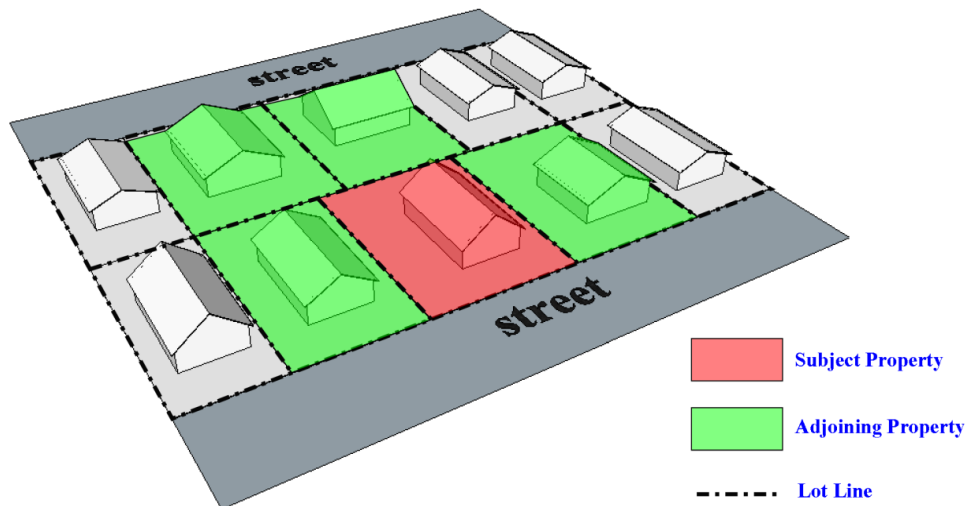

Figure 2B.F3: Adjoin

“**aesthetic screen**” means the technique by which a view of a site or object on a site is shielded, concealed or hidden by means of a fence, wall, hedge, berm or other features.

“**Agriculture**” means a land use class which includes farming such as cultivating land and raising crops and servicing animals. The land use class includes the following land uses:

“**Agriculture, Animal Support**” means a land use where livestock and household animals, are temporarily supported, serviced or treated. Excludes Retail Trade and Assembly land uses.

“**Agriculture, Cannabis**” means a land use that is used for growing of cannabis, excluding processing of the plants other than drying and preparation for distribution. Excludes the Agriculture, Indoor land use

“**Agriculture, Indoor**” means a land use where the farming of plants takes place indoors, excluding the processing of the plants other than preparation for distribution. Excludes the growth of cannabis and the farming of livestock.

“**Agriculture, Outdoor**” means a land use where farming takes place outdoors. Excludes the Open Space, Active land use and the farming of livestock.

“**alley**” or “**lane**” means the same as defined in *The Regina Traffic Bylaw, 1997, No. 9900*.

“**Analysis Guidelines**” means at the discretion of the Development Control Officer, a proposed development within the Downtown Direct Control District may be subject to required analysis.

“**approach surface**” means the same as defined in the *Aeronautics Act, 1989*.

“**Aquifer Protection Plan**” means a comprehensive document that outlines the preventative measures and actions to mitigate potential threats to the existing aquifer.

“**aquifer protection zone, high sensitivity**” means an area overlaying a portion of the Regina Aquifer System where the aquifer is beneath:

- (a) 0 to 5 metres of protective clay or till overburden; or
- (b) 5 to 10 metres of undifferentiated overburden of which the upper portion consists of silty or sandy material.

“**aquifer protection zone, low sensitivity**” means an area overlaying a portion of the Regina Aquifer System where there is a protective clay or till overburden of more than 10 metres.

“aquifer protection zone, moderate sensitivity” means an area overlaying a portion of the Regina Aquifer System where the aquifer is beneath:

- (a) 5 to 10 metres of protective clay or till overburden; or
- (b) more than 10 metres of undifferentiated overburden of which the upper portion consists of silty or sandy materials.

“aquifer sensitive zone” means an area from which water run-off or contaminants released on the surface directly recharges, enters or migrates into an aquifer.

“arcade, sidewalk” means a continuously covered area that functions as a weather-protected extension of the publicly-accessible space that it abuts.

“Architectural Element” means an aesthetic feature consisting of but not limited to a free-standing fence, wall, retaining wall, planter, fountain, pool, gazebo, decorative feature or the like.

“arterial street” means a street with controlled access and intended to provide travel to and from collector streets and expressways.

“artist studio” means a building or portion of a building designated for an artist (e.g. performing, visual and participatory art) to live and work.

“Assembly” means a land use class including land uses where members of the general public gather for a variety of purposes. The land use class includes the following land uses:

“Assembly, Adult” means a land use where members of the general public gather featuring pornographic entertainment, pornographic performance or other similar activities, including but not limited to any activity that, to the discretion of the City, emphasizes the depiction or description of sexual activities or sexualized anatomical areas. Excludes the “Service Trade, Body Rub Establishment” land use.

“Assembly, Ceremonial” means a land use where:

- (a) members of the general public may gather for funeral ceremonies;
- (b) arrange preparation for bodily remains of a person; or
- (c) bodies are prepared for burial or are cremated.

“Assembly, Community” means a land use where members of the general public may gather for community, educational, or cultural activities. Excludes the “Assembly, Adult”, “Assembly, Recreation”, “Assembly, Religious” and “Assembly, Range” land uses and land uses defined in the non-Assembly land use classes.

“Assembly, Range” means primarily an outdoor land use where members of the general public gather to exhibit, train with, instruct or use handheld ranged weapons and similar projectiles (including axes, knives, bow & arrows and firearms).

"Assembly, Recreation" means a land use where members of the general public gather for sports, social, training, spectating or entertainment activities. Excludes "Assembly, Adult", "Assembly, Community", "Assembly Range", "Assembly, Religion land uses as well as land uses defined in non-Assembly land use classes.

"Assembly, Religious" means a land use where members of the general public may gather for spiritual or religious purposes which may include meeting, studying, and worshiping. Excludes "Assembly, Adult", "Assembly Community", "Assembly Range", "Assembly Recreation", as well as land uses defined in non-Assembly land use classes.

– B –

“**block**” means an area bounded by four public streets, excluding a lane.

“**block face**” means one side of a street between two consecutive public land features (such as roads, waterways, publicly-owned easements) that are 10 metres wide or wider and intersect the street (see figure 2B.F4). On a cul- de-sac, lots fronting the traffic bulb form a separate block face

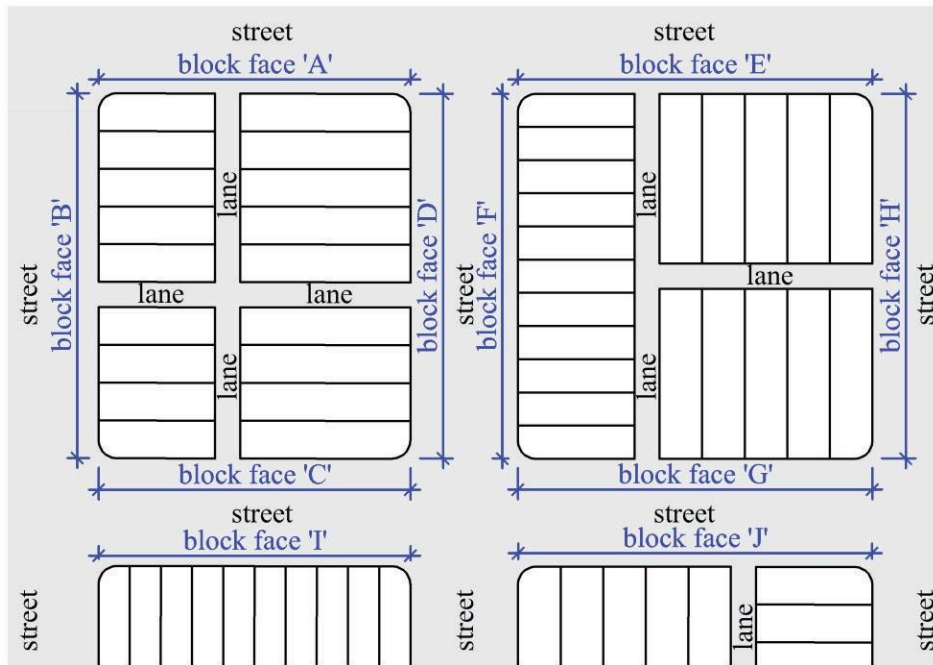

Figure 2B.F4: Block face

“**boulevard**” means as defined in The Regina Traffic Bylaw, 1997, No. 9900.

“**branch line**” means a rail line that provides for:

- (a) volumes generally less than five trains per day; and
- (b) speeds usually limited to a maximum of 50 kilometres per hour.

“**brownfield**” means the same as defined in The Official Community Plan , and includes, without limitation, any site that is the subject of a document filed or registered in the registry established pursuant to *The Environmental Management and Protection Act, 2010*.

“**building**” means a structure used for the shelter or accommodation of persons, animals, goods, possessions or equipment, having a roof which is supported by columns or walls situated on private property when so used. Also means a building class including buildings of various forms. The building class includes the following building types:

“**Building, Accessory**” means a separate building or structure normally incidental, subordinate, exclusively devoted to and located on the same lot as the principal building or structure.

"Building, Detached" means a building on a single lot and contains, either:

- (a) one unit occupying the entire building (see figure 2B.F5a); or
- (b) multiple units attached back-to-back through a common wall extending from foundation to roof (see figure 2B.F5b).

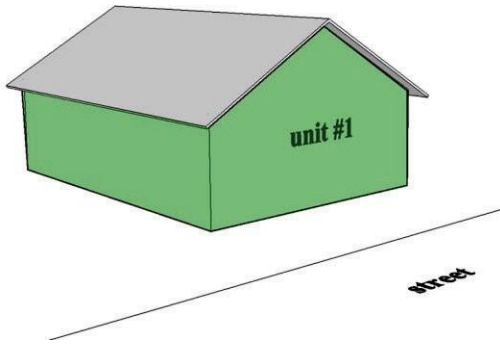

**Figure 2B.F5a: Building, Detached
Building, Detached (One-unit)**

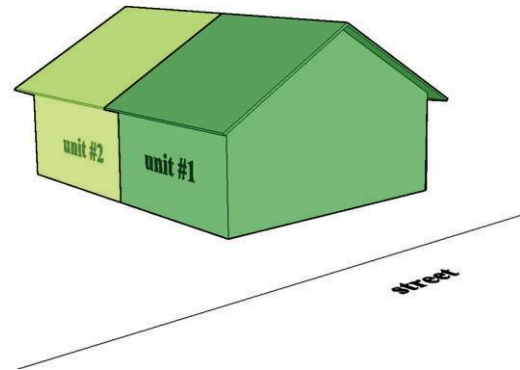

**Figure 2B.F5b:
(Back to Back units)**

"Building, House-Form" means a building as it existed as of March 21, 1984, originally constructed as a one-unit detached building where Dwelling, Unit was the principal use.

"Building, Manufactured Home" means a transportable structure placed atop a frame or chassis and is designed to be transported on its own wheels and chassis or by other means.

"Building, Planned Group" means a development of more than one principal residential building on a lot.

"Building, Principal" means a building that contains at least one principal use.

"Building, Row" means a building containing two or more units, as specified within the zone regulation, while meeting the following conditions:

- (a) The units may be located on the same lot or separate lots and may be subdivided from each other;
- (b) Minimum two units shall be connected side-by-side where through walls extending from foundations to roof; and
- (c) No unit shall be located entirely or partially above the other (see figure 2B.F6).

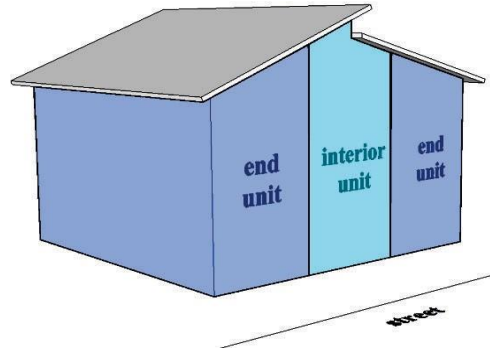

Figure 2B.F6: Building, Row

“**Building, Stacked**” means a building containing two or more units, as specified within the zone regulations, on a single lot with at least one unit entirely or partially above another (see figure 2B.F7).

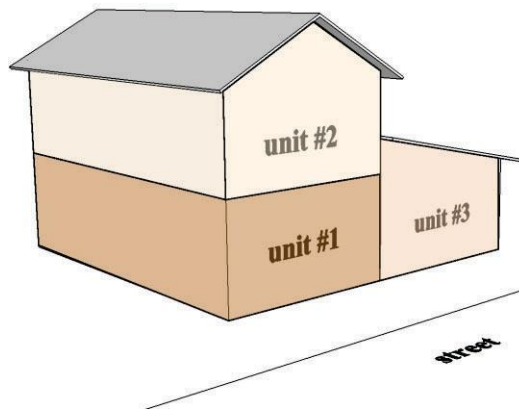

Figure 2B.F7: Building, Stacked

“**building construction drawings**” means a set of technical drawings prepared by a professional Engineer or Architect licenced to perform in the province of Saskatchewan, required for proper execution of the proposed project within the Former Diocese of Qu’Appelle Direct Control District , including architectural, civil, and structural drawings.

“**building permit**” means a permit issued under *The Building Bylaw* of The City of Regina authorizing the construction of a building.

– C –

“**cannabis**” means the same as defined in the Cannabis Act (Canada).

“**cantilever**” means an overhanging part of a structure supported at one end only.

“**Central Business District**” means the same as defined as the area in figure 6A.F9 of the Downtown Direct Control District.

“**ceremonial route**” means street circuits within the city that link important locations or points of interest that are used for government, parade, or other ceremonial occasions.

“**collector street**” means a street that provide for:

- (a) circulation within communities and connectivity between local and arterial roadways; and
- (b) direct access to and from abutting properties.

“**communal amenity area**” means a common space allocated for the recreational use of all residents within the development. The area shall be indoor or outdoor space, or a combination thereof.

“**communications antenna**” means an antenna regulated federally by the *Radiocommunication Act* and subject to the *Radiocommunication and Broadcasting Antenna Systems Client Procedures*.

“**community center**” means a building or facility operated by the City of Regina and open to the general public to use for recreational, social, educational or cultural activities.

“**Council**” means the Council of the City of Regina.

“**coverage**” includes the percentage of the lot which is covered by buildings or structures, excluding uncovered swimming pools, uncovered terraces, uncovered porches and decks, except when the basement walk out area is covered by main floor deck.

“**cultural heritage**” means the intangible practises, expressions, knowledge and skills of a community or an individual in addition to associated material instruments, public art, artifacts, objects, historic places and cultural spaces.

“**curb**” means the same as defined in *The Regina Traffic Bylaw, 1997, No. 9900*.

– D –

“**dangerous goods**” means the same as defined by the *Dangerous Goods Transportation Act, 1985*.

“**datum line**” means an assumed surface used as a reference for the measurement of heights and depths.

“**dedicated outdoor area**” includes a portion of a lot that is outdoors and used primarily for a principal or accessory land use that is separate from required screening, landscaped areas, parking areas and loading areas.

“**development**” means the same as defined in *The Planning and Development Act, 2007*.

“**Development Appeals Board**” means the same as defined in *The Planning and Development Act, 2007*.

“**Development Officer**” means the Executive Director of City Planning & Community Development or his or her designate.

“**development permit**” means a document authorizing a development issued pursuant to this Bylaw.

“**Development Viability Assessment**” means is a report that evaluates any potential conflicts resulting from the proximity of new residential development to neighbouring railway corridors, as well as any impacts on the operation of the railway resulting from the new residential development, including during construction and after.

“**discretionary use**” means a use of land, intensity of use, development or other structure that may be permitted in a zone only at the discretion of and at a location specified by the Development Officer or Council, as the case may be, in accordance with this Bylaw.

“**Drive-Through**” means a land use class including land uses where a good or service is provided to a customer who remains in a motor vehicle. The land use class includes the following land use:

“**Drive-Through, Accessory**” means any ancillary or accessory use where a good and/or a service trade is dispensed or provided to a person who remains in a motor vehicle.

“**driveway**” means a hard surfaced private right-of-way adjoining and providing access for vehicles from a street, boulevard, curb, or sidewalk to a carport, garage or hard surfaced parking pad.

“**Dwelling**” means a land use class where a building is used as a residence. The land use class includes the following land uses:

“Dwelling, Assisted Living” means a dwelling unit in a building designed to accommodate people that require assistance with housekeeping and personal care and which includes common areas for dining and socializing.

“Dwelling, Backyard Suite” means a subordinate, self-contained dwelling unit within an accessory building or portion of an accessory building, in the side or rear yard, on a lot that contains a principal Dwelling, Unit.

“Dwelling, Group Care” means a supervised dwelling unit, licensed or approved under provincial statute, for the accommodation of persons, excluding staff, referred by hospitals, courts, government agencies or recognized social service agencies or health professionals.

“Dwelling, Secondary Suite” means a subordinate, self-contained Dwelling, Unit within a building or portion of a building that contains a principal Dwelling, Unit, and where both dwelling units constitute a single real estate entity.

“Dwelling, Unit” means a self-contained living unit of one or more rooms containing cooking facilities, sanitary facilities, living quarters and/or sleeping quarters.

– E –

“**easement**” means the right, as registered to a property title, to cross or otherwise use another person’s land, usually for a specified purpose.

“**end unit**” means a unit in a Building, Row with a wall adjoining a side yard (see figure 2B.F6).

“**expressway**” means a street that provides for:

- (a) relatively unimpeded traffic flow at high speeds;
- (b) signalized intersections at-grade; and
- (c) no direct access to abutting properties.

– F –

“**façade**” means an exterior wall of a building that fronts a public street (excluding a public lane) or public open space that is visible to persons not within the building.

“**factory-built building**” means a building constructed and labelled under the requirements of the Canadian Standard Association standard CSA A277.

“**fence**” means a barrier, or other upright structure enclosing an area of ground to mark a boundary.

“**flankage yard**” means that part of a corner lot which extends from the front yard to the rear yard between the lot line adjoining a public street and the nearest wall or supporting member of a principal building or structure (see Figure 2B.F8).

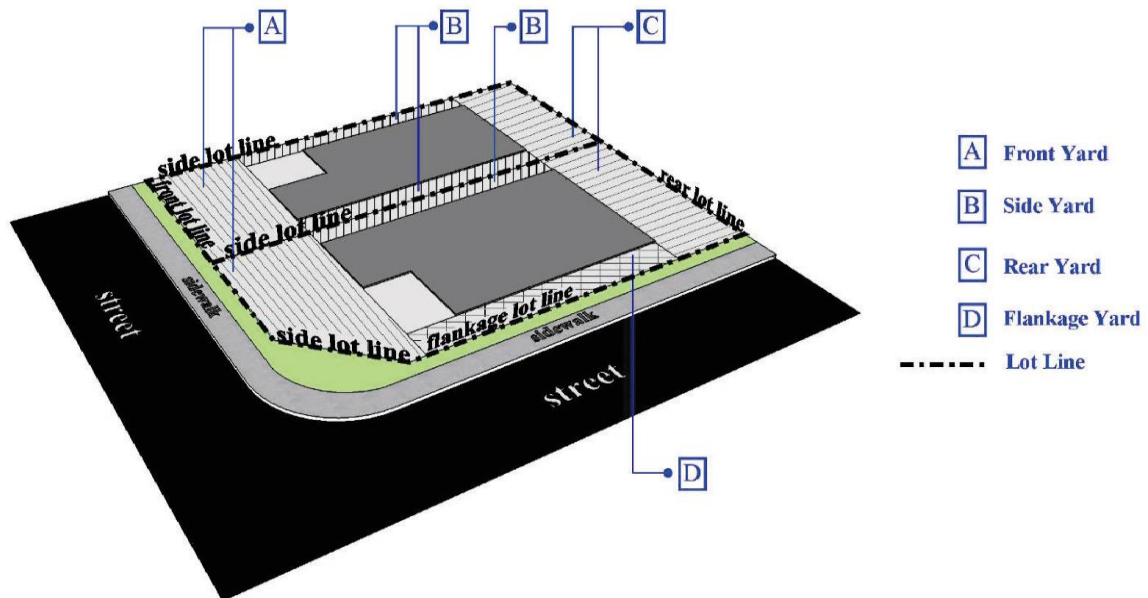

Figure 2B.F8: Yard Definitions

“**floodplain**” means the area prone to flooding from a water body or watercourse that comprises the combined area of the floodway and flood fringe (see Figure 2B.F9).

“**floodway**” means the portion of the floodplain adjoining the channel where the waters in the 1:500 year flood are projected to meet or exceed a depth of one metre or a velocity of one metre per second (see Figure 2B.F9).

“**flood fringe**” means the portion of the floodplain where the waters in the 1:500 year flood are projected to be less than a depth of one metre or a velocity of one metre per second (see Figure 2B.F9).

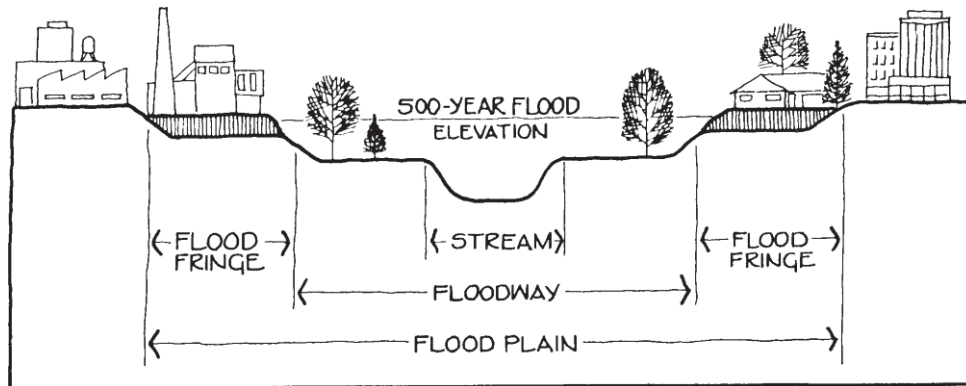

Figure 2B.F9: Typical Floodplain Cross Section

“**floor area**” means the area of a floor in a building or structure, measured between the exterior faces of the exterior walls of the building or structure.

“**floor area ratio (FAR)**” means the gross floor area of all buildings on a lot divided by the lot area.

“**Food & Beverage**” means a land use class of several types, all of which involve the provision of food and beverages to members of the general public. This land use class includes the following land uses:

“**Food & Beverage, Lounge**” means a land use:

- (a) That has received a tavern endorsement or tavern permit under *The Alcohol Control Regulations, 2016*; and/or
- (b) Where food and/or beverages are consumed on-site and commercial entertainment, including dancing or live music is provided on-site; excluding the land use Assembly, Adult.

“**Food & Beverage, Catering**” means a land use where food and/or beverages are prepared for off-site consumption.

“**Food & Beverage, Restaurant**” means a land use where food and/or beverages are prepared for consumption, sold and served to the general public on-site.

“**Food & Beverage, Outdoor**” means primarily an accessory land use, located outside or in a partially enclosed area, where food and/or beverages are served or consumed. This includes, but is not limited to, the outdoor portion(s) of any other land use listed in the Food & Beverage land use class.

“footing elevations” means a numerical figure representing the elevation measured at the top surface of a foundation.

“freeway” means a street that provides for:

- (a) unimpeded traffic flow at high speeds;
- (b) access points that are grade separated; and
- (c) no direct access to abutting properties.

“freight rail yard” means an indoor or outdoor facility where the transfer of containers is performed between freight trains, and where railcars are stored and maintained.

“front,” means, when referring to a site, a lot or land that shares a common boundary line with a public street.

“front lot line” means the line dividing the lot from the street; for a corner lot, the front lot line shall be the lot line on the same street as the front lot lines of lots on the same block face; for a through lot, the front lot line shall be that street line which interfaces most directly with adjacent land uses.

“front yard” means that part of a lot which extends across the full width of a lot between the front lot line and the nearest wall or supporting member of a building or structure (see Figure 2B.F8).

“front yard setback” means the distance between a front lot line and the nearest wall or part of a building.

“frontage” means the distance between the two points where the side lot lines of a lot intersect the boundary of a public street. This term for a corner lot shall reference front lot line.

– G –

“**gateway buildings**” means the buildings that have the greatest visual prominence which are located on the entrance corners of the Downtown Direct Control District.

“**glazing**” means the portion of a building’s wall that is constructed of glass (windows).

“**grade**” means the average elevation of natural ground level at the walls of a building. For the purpose of calculating the height of a building with a walk-out basement, the grade shall be the average elevation of the natural ground level at the wall that is adjacent to the front lot line.

“**gross floor area**” means the total floor area in a building or structure that is primarily indoors, measured between the exterior faces of the exterior walls of the building or structure at the level of each storey:

- (a) at and above grade, in the case of Dwellings in residential zones or below, at and above grade, in the case of all other uses; and
- (b) excludes the area used for off-street unloading, parking, mechanical equipment, stairways or shafts.

“**growing season**” means for the purpose of completing landscaping requirement, May 1 to September 15 of the same calendar year.

– H –

“**habitable space**” means a space in a building for living, sleeping, eating or cooking, hallways and bathing rooms containing toilets excluding closets, storage or utility rooms.

“**hard landscaping**” means the use of non-vegetative materials such as brick, stone, tile or wood, excluding asphalt or concrete for the purpose of surface paving.

“**hazardous material**” or “**hazardous substance**” means as defined in *The Hazardous Substance and Waste Dangerous Goods Regulations*; and

- (1) any other substance that, in the opinion of the Development Officer, is likely to be hazardous to humans, human livelihood, animals (domestic or wild), or likely to harm the general environment.

“**heavy or long combination vehicle route**” means as identified in the *Regina Traffic Bylaw, 1997, No. 9900*.

“**height**” means the vertical distance measured from grade level to the higher of:

- (a) the highest point to the top of the flat roof structure; or
- (b) the mean level between the top of the highest exterior wall plate and the ridge of a pitched roof (see figure 2B.F10).

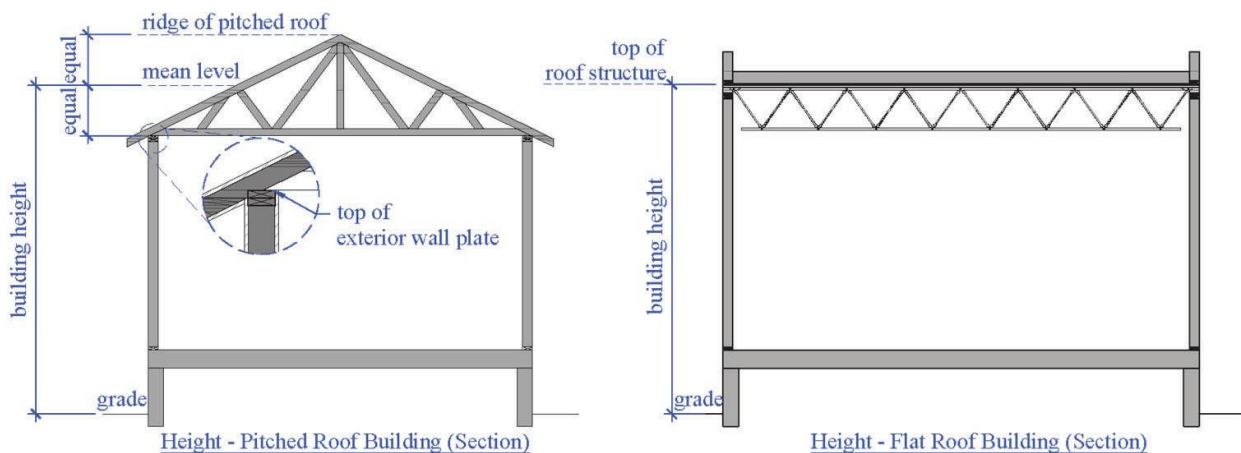

Figure 2B.F10: Height

“heritage property” means any of the following:

- (a) a property designated as a Municipal Heritage Property, Provincial Heritage Property, a property within the boundaries of a Municipal Heritage Conservation District as defined in the *Heritage Property Act*.
- (b) a site that contains archaeological objects;
- (c) a site that contains palaeontological objects;
- (d) any property or site that is of interest for its architectural, historical, cultural, environmental, archaeological, palaeontological, aesthetic or scientific value; or
- (e) any site where Council or the Development Officer are satisfied that any object or property mentioned in subclauses (b), (c) or (d) is or may reasonably be expected to be found.

“horizontal rhythm” means the recurrence at regular intervals of design elements that help make up their visual character and definition in a horizontal fashion

“horizontal surface” means the same as defined in the *Aeronautics Act*.

“household animal” means a domesticated animal kept as a household pet or a personal service animal. Excludes livestock.

– I –

“industrial activity” includes any productive activity that adds value to or finishes a good, a product, merchandise or an article. Such activities may include:

- (a) testing;
- (b) design;
- (c) researching / developing;
- (d) cleaning;
- (e) manufacturing;
- (f) mixing
- (g) processing;
- (h) fabrication;
- (i) assembly;
- (j) treatment; and
- (k) packaging.

Also includes incidental storage and distribution of the inputs and outputs of such activities. Excludes direct sales, retail trade activities, service trade activities and on-site consumption.

“Industry” means a land use class of various types, all of which involve some kind of industrial activity. This land use class includes the following land uses:

“Industry, Artistic” means a land use where an artist, artisan, or similar professional designs, prepares, creates, or repairs artistic, craft or artisanal works, usually by hand or with handheld or household tools and does not include the mass production of similar articles. Includes media production facilities or artistic studios. Excludes any work involving Industry, Light, unprocessed fur; tanning and dyeing, and; butchering, slaughtering or dressing.

“Industry, Food & Beverage” means a land use where industrial activities result in food- and/or beverage-related goods or products, usually to be sold to/by land uses in the Food & Beverage land use class and/or “Retail Trade, Shop” land use.

“Industry, Heavy” means a land use where industrial activities take place, involving:

- (a) welding;
- (b) particulate matter;
- (c) substances which may cause nuisance such as light, glare, odour or noise;
- (d) dangerous goods; or
- (e) hazardous material.

“Industry, Laboratory” means a land use where non-clinical and non-training activities are conducted to contribute to human knowledge by way of information obtained by formal scientific or technological research, development, testing and design, including processes to

create, test, patent or improve material, products or services. Excludes any land use where patients are regularly examined or diagnosed, students are regularly or formally educated, or members of the general public are regularly received as clients.

“Industry, Light” means a land use where industrial activities take place, but excluding the carrying-on production, processing or storage of:

- (a) substance which may cause nuisance such as light, glare, odour or noise;
- (b) particulate matter;
- (c) waste and waste substance;
- (d) welding;
- (e) refining, processing or upgrading of oil and natural gas;
- (f) mining, quarrying, or extraction of oil or natural gas;
- (g) dangerous good as defined by this Bylaw;
- (h) hazardous material as defined by this Bylaw; and
- (i) nuclear or radioactive substance.

“Industry, Salvaging – Light” means a land use located entirely indoors where light salvaging operations take place which includes the collection, packaging, repackaging, purchase and/or processing, as well as temporary storage, of any of the following for the purpose of dismantling, repurposing, reusing, salvaging or recycling:

- (a) paper, metal (including scrap metal) and plastic material;
- (b) glassware, pottery and ceramics;
- (c) clothing, fashion accessories, leather material and textiles;
- (d) computers, computer components and household electronics;
- (e) furniture and household appliances;
- (f) materials that are, in the opinion of the Development Officer, similar to those listed above.

Excludes the collection, storage, sale or purchase of farm equipment, motor vehicles, similar heavy equipment, and accessories of motor vehicle or similar heavy equipment, as well as the storage of hazardous materials including hazardous waste.

“Industry, Salvaging – Heavy” means a land use where heavy salvaging operations take place which includes the collection, packaging, repackaging, purchase and/or processing, as well as temporary storage, of any of the following for the purpose of dismantling, repurposing, reusing, salvaging or recycling:

- (a) paper, metal (including scrap metal) and plastic material;
- (b) glassware, pottery and ceramics;
- (c) clothing, fashion accessories, leather material and textiles;
- (d) computers, computer components and household electronics;
- (e) furniture and appliances;
- (f) construction and landscaping materials;
- (g) wastes, waste materials and rags to be cleaned and reused or recycled;

- (h) farm equipment, motor vehicles and similar heavy equipment;
- (i) tires, motor vehicle components and components for similar heavy equipment;
- (j) materials that are, in the opinion of the Development Officer, similar to the list above.

“Institution” means a land use class including various land uses where organizations provide for members to gather for formal or charitable educational, medical, social or similar purposes. This land use class includes the following land uses:

“Institution, Day Care” means a land use where care, protection and supervision are provided to individuals of any age who require care on a regular, periodic, or temporary basis. This excludes Dwelling, Group Care and includes but is not limited to:

- (a) child care centres as defined by *The Child Care Act, 2014*; and
- (b) a facility which offers educational and social activities for individuals who are not compulsory school age according to *The Education Act, 1995*.

“Institution, Education” means a land use where an accredited person and/or organization provide students with regular, formal, on-site education, instruction, testing or training.

“Institution, Health Care” means a land use where:

- (a) patients may receive or be admitted for on-site health care and/or medical treatment by accredited professional and both in-patient and out-patient activities are permitted;
- (b) bodies are temporarily kept or tended to for autopsy, identification, scientific or educational inquiry, coroner activities.

“Institution, Humanitarian Service” means a land use where a non-profit organization provides direct, on-site social or welfare services to those in need. On-site office activities must be associated with services provided. Typical activities include:

- (a) Information resources;
- (b) Administrative and advocacy services;
- (c) Referral services;
- (d) Skills development;
- (e) The provision of aid and basic needs;
- (f) Life skills training and personal development programs;
- (g) Alcohol, drug or substance abuse rehabilitation;
- (h) Drop-in/activity rooms; and/or
- (i) Activities that are, in the opinion of the Development Officer, reasonably similar to the land uses listed above.
- (j) Shelter

“Institution, Training” means a land use where qualified instructors provide students or apprentices with regular, hands-on or vocational education, instruction, testing or training.

“interior side yard” means the side yard of a lot that does not adjoin a street or a lane.

“interior unit” means a unit between two end units.

– L –

“**landmark frontages**” means the building faces that help define the edges of streets and open spaces within the Downtown Direct Control District.

“**landscaping**” means the modification and enhancement of a site through the use of soft landscaping and/or hard landscaping.

“**land use**” means the purpose that the land serves or the operation on the land.

“**land use class**” means a grouping of similar land uses.

“**light court**” means a recess formed by the outer walls of a building that is accessed using a stoop from the front of a building.

“**livestock**” means the same as defined by the *Regina Animal Bylaw No. 2009-44*.

“**live/work**” means the same as defined in *Design Regina: The Official Community Plan Bylaw 2013-48*.

“**loading stall**” means an off-street parking stall, either outside or within a building, used by motor vehicles during delivery, loading and/or unloading.

“**local street**” means a street designed primarily to provide access to abutting property.

“**long-term bicycle parking (stall)**” means bicycle parking that is secured from theft and vandalism, either by being within:

- (a) A locked, fenced area;
- (b) A locked room within a building; or
- (c) An individual locker that is no less than 200 centimetres by 80 centimetres by 130 centimetres.

Entry to a long-term bicycle parking stall shall be determined by the property owner or designate.

“**lot**” means a parcel or contiguous parcels of land in one ownership.

“**lot line**” means the boundary line of a lot.

– M –

“**main line**” means a rail line that provides for:

- (a) volumes generally exceeds five trains per day; and
- (b) high speeds, frequently exceeding 80 kilometres per hour.

“**maintenance easement**” means a right-of-way, as registered on the title of a lot, granted to use a designated portion of the lot for the maintenance of a building built on the zero lot line on the adjoining lot.

“**major system swale**” means the water-retaining feature(s) of a channel primarily designed to drain water, slow water/drainage velocity, or remove sediments from the water. May be vegetated.

“**Major Roadway**” means a major road right-of-way and/or an intersection that has been identified to have aesthetic importance to the City. These may include but are not limited to a Ceremonial Route, Gateway, Gateway Corridor, Major Arterial or Major Arterial Intersection.

“**major arterial street**” means a street that provides for:

- (a) major traffic flows between major traffic generators and communities;
- (b) no residential frontage;
- (c) no direct access to any land use; and
- (d) median openings only at intersections.

“**minor arterial street**” means a street that is:

- (a) designed to supplement major arterial roadways to provide connectivity between highways and expressways and local and collector street networks; and
- (b) provides for direct access to abutting properties with some access controls.
- (c) designed to supplement major arterial roadways to provide connectivity between highways and expressways and local and collector street networks. Direct access to abutting properties is generally permitted with some access controls.

“**manufactured home park**” means a lot under single management, for the placement of two or more manufactured homes.

“**marquee**” means the same as defined in the *Regina Sign Bylaw*.

“**mixed-use**” means a development that contains both Dwelling and non-dwelling principal land uses.

“**Motor Vehicle, Heavy**” means a large truck, fire truck, semi-tractor, landscaping/construction vehicle, recreational vehicle, farm vehicle or vehicle that, in the opinion of the Development

Officer, is similar in impact to these vehicles.

“Motor Vehicle, Light” or **“Light Motor Vehicle”** means a personal motor vehicle, taxi, limousine or emergency vehicle, excluding a fire truck.

“Municipal Heritage Property” means the same as defined in *The Heritage Property Act*.

– N –

“next-door lot” means a lot that:

- (a) shares side lot lines with; and
- (b) fronts the same street as,

the lot of the proposed development.

“non-intermittent surface water” means a natural or manmade feature that contains water or ice year-round.

“non-permeable surface” means a surface consisting of materials such as concrete, asphalt, unit pavers, and compacted gravel that are not vegetated and do not absorb water.

– O –

“Office” means a land use class of various types, of which the principal use of each type is business, administrative or managerial space for various work activities. This land use class includes the following land uses:

“Office, Industry” means a land use associated with industries or businesses benefitting from close access to major corridors, regional customers, intermodal hubs, etc. This includes those owned or operated by the Municipal, Provincial, or Federal government. Example activities include construction, surveying, engineering, research and development, resource extraction e.g. oil/gas, mining, agriculture, logistics, transportation, warehousing and distribution, catering, utility and real estate companies. Excludes any activity defined as an “Office, Professional” land use.

“Office, Professional” means a land use where non-retail business affairs are conducted, including administrative, managerial, financial or representative workspaces for off-site business. Clients may occasionally be received on-site, but work can regularly be conducted without clients present. This includes those owned or operated by the Municipal, Provincial, or Federal government. Excludes any activity defined as an “Office, Industry” land use.

“Official Community Plan” Refers to Design Regina, Official Community Plan Bylaw No. 2013-48.

“Open Space” means a land use class of various types of which the intent is an entirely or predominantly outdoor environment which incorporates or includes natural physical or man-made elements to provide for passive and active recreation activities or serve a utilitarian function. This land use class includes the following land uses:

“Open Space, Active” means a land use, entirely or predominantly outdoors, set aside for the use, enjoyment and recreation of the general public.

“Open Space, Campground” means a land use, entirely or predominantly outdoors, where tenting and camping-related activities take place.

“Open Space, Ceremonial” means a land use, entirely or predominantly outdoors, where the land is set aside for commemorative or historical purposes.

“overburden” means the natural rock and soil that sits above the body (aquifer) of interest.

– P –

“**permeable surface**” means a groundcover that is capable of absorbing water including materials such as stone mulch, woodchip mulch, shrubs and turf or vegetative elements.

“**permitted use**” means a use of land, intensity of use, development or structure that an owner is entitled to as of right of a development permit provided the use or development conforms to the development standards and regulations which pertain hereto in this Bylaw.

“**pipeline corridor**” means the area used for and around a pipeline as defined in *The Pipelines Act*.

“**planned group**” means a group of two or more principal buildings occupying the same site, provided that each form of development comprising the group is otherwise a permitted or discretionary use in the land zone

“**podium**” means the lower portion of a building with a step back and a higher portion that defines the street edge or public realm. It refers to the overall massing of the lower portion of the building (see Figure 6A.F6(b)).

“**Policy Area**” means any area of the city subject to location-specific policies or regulations as identified in *Design Regina, Official Community Plan Bylaw No. 2013-48*.

“**porch**” means a covered shelter, having direct access to the ground, projecting in front of the entrance to a building which can be open or closed in.

“**principal use**” means the main or primary use and chief purpose of land or structure, as distinguished from a secondary or accessory use.

“**private street**” means a road constructed on private property that has similar features to a public street..

“**prohibited use**” means a use of land, intensity of use, development or structure that is not permissible in a zone.

“**provincial heritage property**” means the same as defined in *The Heritage Property Act*.

“**public amenity**” includes any resource, convenience, facility or benefit meant for use and enjoyment by members of the general public.

“**public art**” includes the works of art, in any media, that have been planned and executed with the specific intention of being sited or staged in the public domain, often incorporating elements of site specificity, cultural heritage, community engagement, and collaboration.

“**public gallery**” means a space containing fixed seating for public assembly for the purpose of entertainment or cultural events and encouraging the development of the performing arts.

“public realm” means places and or spaces that are shared by the public. This includes all public places, open spaces and streetscapes.

“public restroom” means a room containing one or more toilets, and possibly lavatories or showers, for use by members of the general public.

“public street” means a road or thoroughfare that is owned and operated by the City of Regina and may include a public sidewalk.

“Public Use” means a land use class where the intent of the land use is its accessibility to members of the general public. This land use class includes the following land uses:

“Public Use, General” includes any land use, other than those in the “Office” land use class, which is owned or operated by the Municipal, Province, or Federal government or an authorized agent of one of these governments for the distribution of public goods and/or services to benefit Regina’s residents. Includes any accessory structures, accessory buildings and accessory uses necessary for the operation and general maintenance of the use.

– R –

“**rear lot line**” means the lot line or point of intersection of the side lot lines farthest from and opposite the front lot line.

“**rear yard**” means that part of a lot which extends across the full width of a lot between the rear lot line and the nearest wall or supporting member of a principal building or structure (see Figure 2B.F8).

“**rear yard setback**” means the distance between a rear lot line and the closest wall or part of a building.

“**recreational vehicle**” means a vehicle, portable structure, or watercraft including a trailer on which a portable structure or watercraft is mounted, that can be towed, hauled, carried on a vehicle or trailer or driven and which is designed to be used for travel or recreational purposes, which does not include a snowmobile but does include but is not limited to a motor home, travel trailer, fifth wheel trailer, tent trailer, truck camper, boat, canoe, kayak, all-terrain vehicle, jet ski, or other similar vehicle.

“**Residential Business**” means an accessory land use conducted in a Dwelling Unit by the resident of the Dwelling Unit for monetary gain.

“**Retail Trade**”: A land use class of various land use types where the principal activity involves the sale of goods to members of the general public. This land use class includes the following land uses:

“**Retail Trade, Adult**” means a land use where pornographic material – including but not limited to material that, in the opinion of the Development Officer, emphasizes the depiction or description of specified sexual activities or sexualized anatomical areas – is sold or leased.

“**Retail Trade, Cannabis**” means a land use, licensed by the Saskatchewan Liquor and Gaming Authority, where only cannabis for recreational purposes and cannabis accessories are sold to persons who attend the premises.

“**Retail Trade, Fuel Station**” means a land use primarily intended for the sale of fuel for Motor Vehicles, Heavy and/or Light.

“**Retail Trade, Motor Vehicle – Light**” means an indoor or outdoor land use intended for sale, lease, or rental of light motor vehicles, accessories, and similar sized vehicles.

“**Retail Trade, Motor Vehicle – Heavy**” means an indoor or outdoor land use intended for sale, lease, or rental of heavy motor vehicles and motor vehicle accessories.

“**Retail Trade, Outdoor Display**” means an outdoor land use intended for the sale of flowers, plants, pre-prepared food products, fruit, vegetables, arts, crafts or other merchandise that is, in the opinion of the Development Officer, similar to these products, generally sold by item (rather

than in groups) and used or consumed off-site. Excludes Retail trade, Outdoor Lot and Retail Trade, Adult.

“Retail Trade, Outdoor Lot” means an outdoor land use intended for the sale or lease of lumber, construction motor vehicles and motor vehicle accessories. Excludes “Retail Trade, Adult; Retail Trade, Motor Vehicle – Light; Retail Trade, Motor Vehicle – Heavy.

“Retail Trade, Shop” means an indoor land use intended for the sale or lease of food, beverages, goods, products, merchandise, articles or things to members of the general public but used or consumed off-site. Excludes “Retail Trade, Adult.

“Rhythm” means the recurrence at regular intervals of design elements that help make up their visual character and definition.

– S –

“Self-contained” means a unit having its own kitchen, bathroom, lavatory, and entrance, not shared by other units.

“Sensitive lot” means a lot that may have specific concerns with nearby land uses or land use intensities and warrants a more thorough review and includes any of the following:

- (a) a lot zoned:
 - (i) Residential;
 - (ii) Mixed-Use;
 - (iii) Institutional; or
 - (iv) Direct Control District;
- (b) land that is not under the jurisdictional authority of the City; or
- (c) a lot containing a land use or development that the City considers sensitive to potential impacts or nuisances of a proposed discretionary use.

“separation distance” means a minimum distance between two land uses, which may be on the same lot or on a different lot.

“service street” means a street adjacent to a highway, freeway, expressway, or major arterial, providing direct access to abutting properties.

“Service Trade” means a land use class of various land use types where services are provided to members of the general public. This land use class includes the following land uses:

“Service Trade, Accommodation” means a land use which offers one or more units for transient lodging accommodation to the general public.

“Service Trade, Body Rub Establishment” means a land use where:

- (a) services are offered, solicited or administered to the human body for sensual or sexual pleasure; or
- (b) the primary function of the activity offered, solicited, advertised or administered is kneading, rubbing, touching, massage or other stimulation of the human body by a person who is not an active member in good standing of either the Massage Therapist Association of Saskatchewan, Inc., the Natural Health Practitioners of Canada or the Canadian Massage & Manual Osteopathic Therapists Association.”; or

- (c) a premise advertised as or equipped or arranged to provide the services described in (a) and includes but is not limited to a service advertised as “sensual”, “sexy” or by any other word or any depictions having like meaning or implication.

Excludes the land use **Assembly, Adult**

“Service Trade, Clinic” means a land use where an accredited member of a medical, health care, therapeutic, or counselling profession provides services of a preventative, diagnostic, therapeutic, rehabilitative or counseling nature on an out-patient basis. For the purposes of massage services an accredited member shall mean an active member in good standing with the Massage Therapist Association of Saskatchewan, Inc., the Natural Health Practitioners of Canada or the Canadian Massage & Manual Osteopathic Therapists Association. Excludes land uses in the Institutional land use class and any land use that allows clients to stay in facility overnight.

“Service Trade, Heavy” means a land use where tools, goods, machinery and equipment, including tools large household appliances, commercial scale operations, building and specialized trade, landscaping, and construction are operated, serviced, repaired or maintained, including commercial publishing and printing. Excludes tools, goods, machinery and equipment associated with farming or motor vehicles.

“Service Trade, Light” means a land use where handheld tools and appliances and household items and equipment are operated, serviced, repaired or maintained with service offered to members of the general public. Excludes tools, items, machinery and equipment associated with motor vehicles, commercial scale operations, large household appliances, building and specialized trade, landscaping, construction, and farming.

“Service Trade, Motor Vehicle – Heavy” means a land use where heavy motor vehicles are maintained, repaired or serviced. May include sales of and services related to lubricating oils, fuel, tires or other motor vehicle accessories. Excludes the sales of motor vehicles as well as any land use classified as a Service Trade, Wash - Heavy and Service Trade, Wash - Light.

“Service Trade, Motor Vehicle - Light” means a land use where light motor vehicles are maintained, repaired or serviced. May include sales of and services related to lubricating oils, fuels, tires or motor vehicle accessories to members of the general public. Excludes the sales of motor vehicles as well as any land use defined as Service Trade, Wash – Light, Service Trade, Wash – Heavy or Service Trade, Motor Vehicle – Heavy.

“Service Trade, Personal” means a land use where members of the general public may purchase services associated with grooming or non-clinical appearance and body alterations for people or domestic animals. Excludes any services or activities involving agricultural animals.

“Service Trade, Residential Short Term Accommodation” means a dwelling unit where short-term accommodation is provided

“Service Trade, Wash – Heavy” means a land use which offers washing facilities, whether automated or manual, for heavy motor vehicles.

“Service Trade, Wash – Light” - means a land use where members of the general public may access personal motor vehicle washing facilities, whether automated or manual. Excludes any land use classified as a “Service Trade, Wash – Heavy.”

“shared yard” means that part of the rear yard for use by a principal dwelling unit and a dwelling, backyard suite for active or passive recreation use.

“short-term accommodation” means the provision of sleeping and bathing quarters for less than 30 days, for a fee.

“short-term bicycle parking (stall)” means a parking stall designated for a bicycle where the bicycle can be temporarily secured.

“side lot line” means a lot line other than a front or rear lot line.

“side yard” means that part of a lot which extends from a front yard to the rear yard between the side lot line of a lot and the nearest wall or supporting member of a building or structure, except where the supporting member is supporting an uncovered patio or uncovered sundeck (see Figure 2B.F8).

“side yard setback” means the distance between a side lot line and the closest wall or part of a building.

“single side yard” means one side yard of a lot, but excluding a flankage yard.

“site plan” means a document which indicates the location of all existing and proposed development on a site.

“soft landscaping,” means the use of living plant materials such as trees, shrubs, hedges, grass and other ground covers plus the modification of the landform, such as by berming and terracing.

“specific needs” means the same as defined in *Design Regina: The Official Community Plan Bylaw 2013-48*.

“spur line” means a rail line that provides for:

- (a) unscheduled traffic on demand basis only; and
- (b) speeds usually limited to a maximum of 24 kilometres per hour.

“statistical inventory reconciliation” means an approved monthly monitoring method for underground storage tanks (USTs) and piping as outlined in the *Environmental Code of Practice for Aboveground and Underground Storage Tank Systems Containing Petroleum and Allied Petroleum Products*.

“**stoop**” means a set of stairs or a ramp that connects a building entrance to the sidewalk.

“**storefront**” means a portion of a façade oriented to face a public street to receive patrons.

“**Storage**” means a land use class including various land uses where the principal activity is the storage of goods. This land use class includes the following land uses:

“**Storage, Hazardous Material**” means a land use primarily engaged in the storage of hazardous material(s) and/or dangerous goods. Excludes retail trade activities. Excludes any production, processing or use other than storage.

Includes the storage of any:

- (a) substance which may cause impacts or nuisance such as particulate, odour, glare or noise;
- (b) waste and waste substance;
- (c) dangerous good as defined by this Bylaw;
- (d) hazardous material as defined by this Bylaw; and Excludes the storage of any nuclear or radioactive substances.

“**Storage, Personal**” means a land use where separate, secured indoor storage units are designed to be rented or leased for private storage of personal goods, substances and equipment, household goods, furniture, general merchandise and vehicles. Excludes retail trade activities and the storage of any items listed in the land use Storage, Hazardous Material including any nuclear or radioactive substances.

“**Storage, Warehousing**” means a land use primarily engaged in indoor storage, including (but not limited to) goods or products stored on behalf of commercial or industrial clients or institutional uses. Warehousing may include the indoor storage (short or long-term) of motor vehicles that are unregistered, uninsured and/or inoperable.

Excludes retail trade activities. Excludes the storage of any:

- (a) substance which may cause impacts or nuisance such as dust, odour, glare or noise;
- (b) waste and waste substance;
- (c) dangerous goods as defined by this Bylaw;
- (d) hazardous material as defined by this Bylaw; and
- (e) nuclear or radioactive substances.

“**Storage, Outdoor**” means a land use primarily engaged in the outdoor storage, including (but not limited to) goods or products stored in association with or on behalf of institutional, commercial or industrial land uses or clients. Excludes retail trade activities.

Excludes the storage of any:

- (a) substance which may cause impacts or nuisance such as dust, odour, glare or noise;
- (b) waste and waste substance;

- (c) dangerous good as defined by this Bylaw;
- (d) hazardous material as defined by this Bylaw; and
- (e) nuclear or radioactive substance.

“store” means, as a verb and with respect to hazardous material or dangerous goods, any instance where hazardous material or dangerous good(s) are kept but not otherwise processed, produced or used to manipulate another product on-site.

“street” means the whole and entire width of every highway, public road, or road allowance and shown as such on a Plan of Survey registered with Information Services Corporation.

“street wall” means either:

- (a) in a case where a building has a podium: any wall of a building’s podium that faces a public street (excluding a public alley), public sidewalk, public walkway or public open space; or
- (b) in a case where a building does not have a podium: any wall of a building that faces a public street (excluding a public alley), public sidewalk, public walkway or public open space.

“structure” mean anything constructed or erected, the use of which requires location on the ground or attachment to something located on the ground. Excludes curbs, pavements, walks or open air surfaced areas or moving vehicles.

“substantial addition” means when the gross floor area of an addition to an existing building is greater than 50 percent of the gross floor area of the existing building. This requires the implementation of all development standards and regulations for the land use zone.

– T –

“tandem parking” means two or more parking spaces, one behind the other, with a common or shared point of access to a manoeuvring lane or street.

“threshold” means the maximum intensity, usually expressed as the maximum gross floor area, to which a land use is listed as permitted in a zone or area.

“total site landscaped area” means the total amount of landscaping required for the land zone on the lot.

“total side yard” means the sum of all side yards of a lot.

“Transportation” means a land use class of various land use types, the intent of which is the short-term storage of motor vehicles. This land use class includes the following land uses:

“Transportation, Parking Lot” means an outdoor land use where motor vehicles that are registered, insured and in working order are parked outdoors or in primarily unenclosed areas for temporary intervals.

“Transportation, Parking Structure” means an indoor land use where motor vehicles that are registered, insured and in working order are parked indoors or in primarily enclosed areas for temporary intervals.

“Transportation, Parking Stand” means a land use where motor vehicles primarily used to regularly transport members of the general public actively await dispatch, usually with a driver present on the same lot as the vehicle. Excludes any land use defined as “Service Trade, Motor Vehicle – Light” or “Service Trade, Motor Vehicle - Heavy.”

This land use may be oriented, in whole or in part, for taxis, emergency vehicles and/or limousines.

“Transportation, Terminal” means a land use primarily oriented to the transportation of goods or freight.

– U –

“unit” means: an entire building, or an enclosed area in a building that can be accessed without requiring or resulting in access to any other portions of the building other than a shared space. A dwelling unit may be deemed a unit if it meets the definition of “Dwelling, Unit” land use as defined in this chapter.

“Urban Centre” means the same as defined and identified in *Design Regina, Official Community Plan Bylaw No. 2013-48*.

“Urban Corridor” means the same as defined and identified in *Design Regina, Official Community Plan Bylaw No. 2013-48*.

“Urban Forest” Repealed (#2020-33, s.20, 2020)

“Utility” means a land use class including land uses where the principal activity involves the distribution of utility services by a private entity. This land use class includes the following land use:

“Utility, General” means any development, building, structure or land use owned by a private entity that, in the opinion of the Development Officer, is principally concerned with the provision of utilities – including, but not limited to: drinking water, stormwater, sewage, electricity or telecommunications. This excludes any use in the Office, land use class.

–V–

“**vertical rhythm**” means the recurrence at regular intervals of design elements that help make up their visual character and definition in a vertical fashion.

“**view terminus**” means the end point of a view corridor, often accentuated through design elements such as public art, adding/subtracting from the building mass, or landscaping.

–W–

“**water feature**” means a structure that may include a fountain, cascade, stream water, pond, decorative feature or mirror image.

“**Wholesale Trade**” means a land use class including various land use types where the principal activity is the sale or exchange of goods, though typically not to members of the general public. This land use class includes the following land uses:

“**Wholesale Trade, Indoor**” means an indoor land use where food, beverages, goods, products, merchandise, articles or things are sold or distributed to and temporarily stored for commercial retailers, industrial uses, agricultural uses, institutional uses, professional uses or other wholesalers but generally not to members of the general public.

“**Wholesale Trade, Outdoor**” means an outdoor land use where goods, products, merchandise, articles or things are sold or distributed to and temporarily stored for commercial retailers, industrial uses, agricultural uses, institutional uses, professional uses or other wholesalers but generally not to members of the general public.

“**Work Camp**” means a temporary residential land use intended to provide accommodation for employees or contractors of industrial or construction operations. Without restricting the generality of the foregoing, a Work Camp is usually comprised of a number of mobile units, clustered in such a fashion as to provide sleeping, food preparation, eating and other basic living facilities. Work Camp excludes manufactured home park.

–Y–

“**yard**” means the open, uncovered space located on the same lot as a building, and unoccupied by buildings or structures except as specifically permitted elsewhere in this Bylaw. In determining yard measurements the minimum horizontal distance from the respective lot lines shall be used (see Figure 2B.F8).

-Z-

“**zero lot**” means a lot which contains a principal building built to a zero lot line.

“**zero lot line**” means the side lot line on which one or more of the principal building’s sides rests directly or is within the setback specified in the development standards table for the applicable zone.

“**zone**” means a classification type that the City of Regina applies to land to establish regulations and standards for the subdivision, use and development of that land. The Zoning Bylaw includes the following zones:

- “**AC**” means Architectural Control.
- “**AP**” means Aquifer.
- “**C**” means Contract.
- “**DCD-D**” means Downtown Direct Control District.
- “**DCD-LHP**” means Laneway Housing Pilot Direct Control District.
- “**DCD-RExG**” means Regina Exhibition Grounds Direct Control District.
- “**DCD-QP**” means Former Diocese Qu’Appelle Lands Direct Control District.
- “**DCD-SD**” means Saskatchewan Drive/North Railway Street Direct Control District.
- “**DCD-TAN**” means Transitional Area Neighbourhood Direct Control District.
- “**DCD-WH**” means Warehouse District Direct Control District.
- “**DEN**” means Residential Density.
- “**FA**” means Floor Area.
- “**FW**” means Floodway.
- “**H**” means Holding.
- “**HT**” means Height.
- “**I**” means Institutional.
- “**IH**” means Industrial Heavy.
- “**IL**” means Industrial Light.
- “**IP**” means Industrial Prestige.
- “**LA**” means Lane Access way and Garden Suite.
- “**LGS**” means Laneway and Garden Suite.
- “**MH**” means Mixed High-rise.
- “**ML**” means Mixed Low-rise.
- “**MLM**” means Mixed Large Market.
- “**NEF**” means Noise Exposure.
- “**OA**” means Office Area.
- “**PL**” means Pipeline Corridor.
- “**R1**” means Residential Detached.
- “**RH**” means Residential High-rise.
- “**RID**” means Residential Infill Development.
- “**RL**” means Residential Low-rise.
- “**RMH**” means Residential Manufactured Home.
- “**RN**” means Residential Neighbourhood.
- “**RS**” means Railway Setback.
- “**RU**” means Residential Urban.

“**RW**” means Railway

“**UH**” means Urban Holding.

(#2020-33, s.12-21, 2020, #2020-45, s.5, 2020, #2020-47, s.5-7, 2020, #2020-11, ss. 2-6, 2020, #2020-64, s.5-7, 2020, #2021-2, ss. 7-8, 2021, #2021-31, ss.4-7, 2021, #2021-62, s. 6, 2021, #2022-4, s. 5, 2022, #2022-30, ss.14-18, 2022, #2022-41, ss. 4-8, 2022, #2023-23, ss. 8-11, 2023)

PART 2C

LAND USE SPECIFIC REGULATIONS

2C.1 RESIDENTIAL BUSINESS

1.1 MAXIMUM FLOOR AREA

- (1) The gross floor area of the building used for the principal Dwelling Unit shall include any garage or accessory building.
- (2) Where more than one “Residential Business” is approved on a property, all Residential Businesses together shall not exceed the applicable permitted or discretionary area requirements of the zone.

1.2 PERMITTED AND PROHIBITED RESIDENTIAL BUSINESSES

- (1) A “Residential Business” shall be a land use defined in Part 2B of this chapter, except those listed in Subsection 2C.1.2(3).
- (2) Notwithstanding the permitted or discretionary area requirements of the zone, a “Residential Business” shall not be approved if, in the opinion of the Development Officer, the use would be more appropriately located in a mixed-use or industrial zone having regard for the overall compatibility of the use with the residential character of the area.
- (3) The following land uses or land use classes are prohibited as a “Residential Business” in any zone:
 - (a) any land use in the “Agriculture” land use class, except “Agriculture, Indoor”;
 - (b) any land use in the “Assembly” land use class;
 - (c) any land use in the “Drive- Through” land use class;
 - (d) any land use in the “Dwelling” land use class;
 - (e) any land use in the “Food & Beverage” land use class, except “Food and Beverage, Catering”;
 - (f) any land use in the “Industry” land use class, except “Industry, Artistic”;
 - (g) any land use in the “Institution” land use class, except “Institution, Training” and “Institution, Day Care”;
 - (h) any land use in the “Open Space” land use class;

- (i) any land use in the “Retail Trade” land use class;
- (j) any land use in the “Service Trade” land use class except “Service Trade, Personal,” “Service Trade, Clinic”, “Service Trade, Light” and “Service Trade, Residential Short-Term Accommodation”;
- (k) any land use in the “Transportation” land use class;
- (l) any land use in the “Wholesale Trade” land use class;
- (m) any land use in the “Public Use” land use class; and,
- (n) any land use in the “Utility” land use class.

1.3 EXTERIOR SIGNAGE

No exterior storage or exterior operation of the “Residential Business” shall be permitted.

1.4 MERCHANDISE DISPLAY AND SALE

- (1) No window display of merchandise shall be permitted
- (2) Notwithstanding Clause 2C.1.2(3)(i), merchandise created, assembled or designed on-site may be stored, displayed and sold from the business.

1.5 DEFINED LAND USE

A “Residential Business” falling under the discretionary area requirements of the zone shall only be considered in locations designated, as “live/work” areas through a secondary or concept plan.

2C.2 DWELLING, SECONDARY SUITE

2.1 LOCATION

- (1) Where a “Dwelling, Secondary Suite” land use is listed in the Permitted and Discretionary Land Uses table of a zone, it shall be restricted as shown in Table 2C.T1.
- (2) A “Dwelling, Secondary Suite” is not permitted in an accessory building or structure, unless otherwise specified; and
- (3) No more than one “Dwelling, Secondary Suite” per principal Dwelling Unit shall be located in a building.
- (4) A Dwelling, Secondary Suite shall not be located on a lot where there is already a Dwelling, Backyard Suite.

(#2022-41, s. 9, 2022)

TABLE 2C.T1: SECONDARY SUITE BUILDING TYPES AND ZONES		
Sec.	Building Type	Zone
T1.1	<ul style="list-style-type: none"> • Building, Detached (with only one principal Dwelling Unit) 	<p>(1) Residential Zones:</p> <ul style="list-style-type: none"> (a) RN – Residential Neighbourhood (b) RU – Residential Urban (c) RL – Residential Low-rise (d) R1 – Residential detached <p>(2) Industrial Zones:</p> <ul style="list-style-type: none"> (a) IL – Industrial Light <p>(3) Direct Control Districts:</p> <ul style="list-style-type: none"> (a) DCD-D – Downtown Direct Control District (b) DCD-LHP – Laneway Housing Pilot Direct Control District (c) DCD-QP - Former Diocese Of Qu’Appelle Lands Direct Control District: <ul style="list-style-type: none"> (i) Heritage Policy Area (ii) Low Density Residential Policy Area (iii) Medium Density Residential Policy Area (iv) High-rise Residential Policy Area (d) DCD-CS – Centre Square Direct Control District: <ul style="list-style-type: none"> (i) Low-rise and House-Form Mix (ii) Mid-rise and House-Form Mix (iii) High-rise Mix (iv) Transitional Area Mixed (v) Transitional Area Arterial <p>(4) Special Zones:</p> <ul style="list-style-type: none"> (a) I – Institutional (b) UH – Urban Holding

TABLE 2C.T1: SECONDARY SUITE BUILDING TYPES AND ZONES		
Sec.	Building Type	Zone
T1.2	• Building, Row	(1) Residential Zones: (a) RL – Residential Low-rise (b) RH – Residential High-rise (2) Direct Control Districts: (a) DCD-D – Downtown Direct Control District (b) DCD-QP - Former Diocese Of Qu'Appelle Lands Direct Control District: (i) Heritage Policy Area (c) DCD-CS – Centre Square Direct Control District: (i) Low-rise and House-Form Mix (ii) Mid-rise and House-Form Mixed (iii) High-rise Mix (iv) Transitional Area Mixed (v) Transitional Area Arterial

2.2 FLOOR AREA

(1) a “Dwelling, Secondary Suite” shall not occupy more than the lesser of:

- (a) 40 per cent of the gross floor area of the building; or,
- (b) 80 square metres,

where the calculation of the gross floor area for the purpose of Subsection 2C.2.2 (1) shall include the area of the basement.

(2) The floor area occupied by a Secondary Suite shall be considered as part of the principal building.

2C.3 DWELLING, BACKYARD SUITE

3.1 Location

- (1) Where a Dwelling, Backyard Suite land use is listed in the Permitted and Discretionary land Uses table of a zone, it shall be restricted as shown in Table 2C.T2.
- (2) No more than one Dwelling, Backyard Suite per principal Dwelling unit shall be located on one lot.
- (3) A Dwelling, Backyard Suite shall not be located on a lot where there is already a Dwelling, Secondary Suite within the principal building.

TABLE 2C.T2: BACKYARD SUITE BUILDING TYPES AND ZONES		
Sec.	Building Type	Zone
T2.1	<ul style="list-style-type: none"> • Building, Detached 	(1) Residential Zones: (a) RN – Residential Neighborhood (b) RU – Residential Urban (c) RL – Residential Low-rise (d) R1 – Residential Detached
T2.2	<ul style="list-style-type: none"> • Building, Row 	(1) Residential Zones: (a) RL – Residential Low-rise (b) RH – Residential High-rise (c) RN – Residential Neighborhood (d) RU – Residential Urban

(#2023-92, s. 4, 2023)

3.2 Floor Area

(1) A Dwelling, Backyard Suite shall not have a Floor Area more than the lesser of :

- (a) Floor area of the principal dwelling; or
- (a) 80 square metres,

where the calculation of gross floor area shall exclude the portions of the Accessory Building used as a garage.

(2) The floor area occupied by a Dwelling, Backyard Suite shall be considered as part of the principal building.

(#2023-92, s. 5, 2023)

3.3 Dwelling Backyard Suite Design

(1) A basement suite is not permitted within a Dwelling, Backyard Suite.

(2) An accessible walkway, connecting the street or lane to the Dwelling, Backyard Suite, shall be provided and be no less than 1.2 metres wide.

(3) Balconies in a Dwelling, Backyard Suite shall orient towards a public right of way, the shared yard, or an Open Space, Active land use.

(#2022-41, s. 10, 2022)

PART 2D

SITE DESIGN STANDARDS

2D.1 PARKING AREA STANDARDS

1.1 STALL AND DRIVEWAY DIMENSIONS

- (1) The minimum parking stall and driveway sizes shall comply with Table 2D.T1 depending on the use which the spaces are designed to serve.
- (2) Spaces and aisle dimensions may be designed to a specific standard or a mix of different arrangements, as illustrated in Figure 2D.F1.
- (3) Notwithstanding Table 2D.T1, where 90-degree parking spaces are provided adjacent to an alley measuring 6.096 metres or less, the length of the parking spaces shall be a minimum of 7.5 metres, in order to ensure compliance with the requirements of section 3.8 to provide adequate manoeuvring space.

TABLE 2D.T1: PARKING AREA STANDARDS					
ANGLE OF PARKING (IN DEGREES)		MINIMUM REQUIRED STALL WIDTH (IN METRES)	MINIMUM REQUIRED CURB LENGTH PER CAR (IN METRES)	MINIMUM REQUIRED STALL LENGTH (IN METRES)	MINIMUM REQUIRED DRIVEWAY WIDTH (IN METRES)
0	Option 1	2.5	6.5	2.5	4.0
30	Option 1	2.5	13.95	5.17	4.0
	Option 2	2.73	14.32	5.11	4.0
45	Option 1	2.5	9.55	6.01	4.0
	Option 2	2.73	9.68	5.82	4.0
60	Option 1	2.5	6.61	6.45	5.5
	Option 2	2.73	6.69	6.13	5.5
90	Option 1	2.5	2.5	6.0	7.5
	Option 2	2.73	2.73	5.5	7.5
COMPACT SPACE					
30	Sole Option	2.29	12.25	4.43	2.8
45		2.29	8.31	5.08	3.1
60		2.29	5.75	5.39	5.3
90		2.29	2.29	4.9	7.0

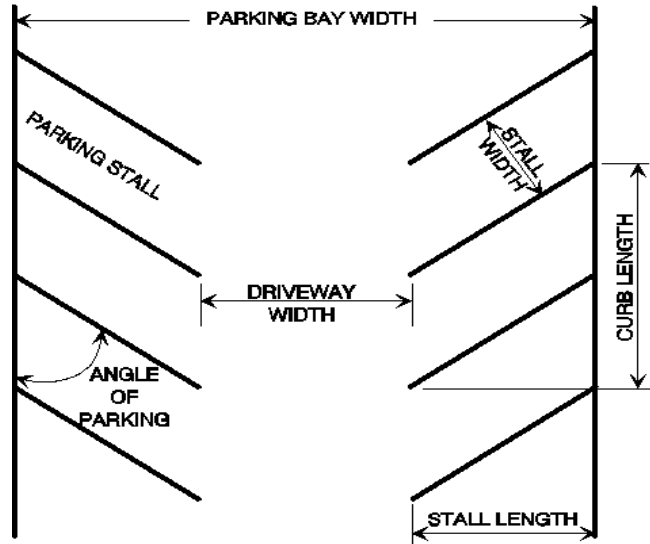

Figure 2D.F1: Illustration of Parking Area

1.2 APPROACH RAMP LOCATION

- (1) The location of vehicular approach ramps or driveways at the street line shall be no closer than 10 metres from the point of intersection of the two curbs at a street intersection.
- (2) Where:
 - (a) the approach ramp will provide access to a parkade that will be part of a new building or part of an addition to an existing building; and
 - (b) there will be a grade difference from the parkade to the street or alley;
 the ramp shall provide a flat area of not less than 5.5 metres and with a maximum slope of 2% for vehicles to stop before they proceed to enter the street or alley (refer to Figure 2D.F2).

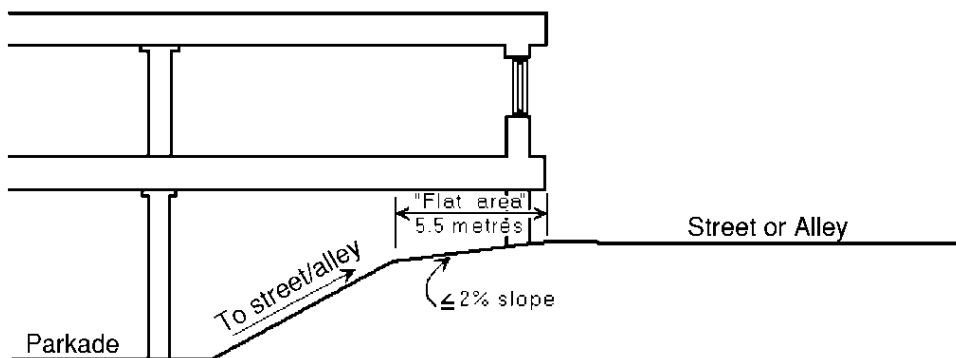

Figure 2D.F2: Ramp Design Illustration

(2022-30, s. 19, 2022)

2D.2 FENCE STANDARDS

2.1 FENCE HEIGHT STANDARDS

Subject to the Intersection Sight Line Control regulations of the Regina Traffic Bylaw, and other Bylaws of the City, in residential zones, the height of a fence above the ground level measured at any point along the fence line shall not exceed:

- (1) for the portion of the fence located in or bordering the front yard 1.22 metres; and
- (2) for the portion of the fence located in or bordering the rear, side or flankage yard:
 - (a) 2.14 metres; or
 - (b) 2.44 metres if adjacent to Arterial Street or Expressway

(See Figure 2D.F3).

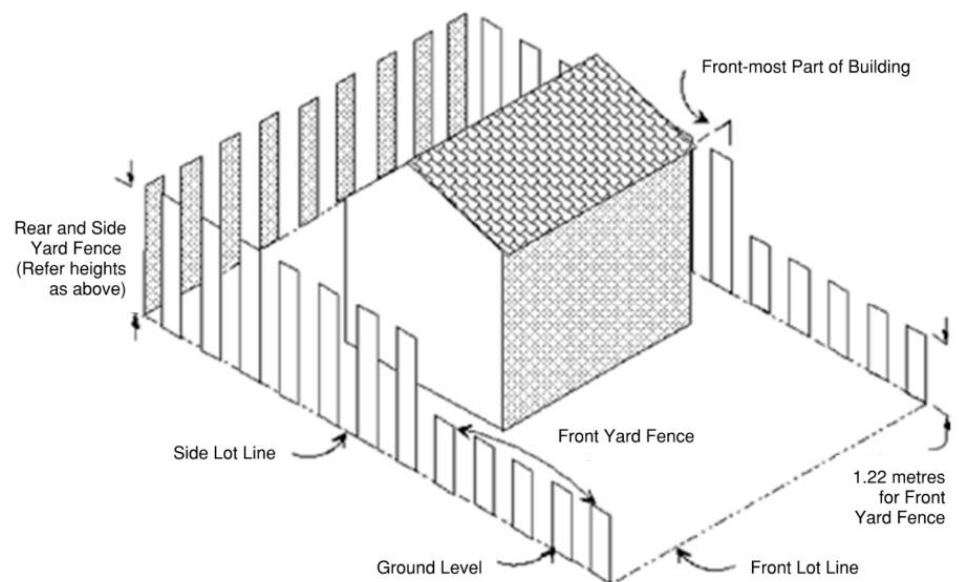

Figure 2D.F3: Fencing Requirements

(2023-47, s. 6, 2023)