

THE  
DIOCESE PROPERTY

---

ARCHITECTURAL CODES

*prepared for*

THE  
CITY OF REGINA

*by*



JENKINS & ASSOCIATES  
ARCHITECTURE & TOWN PLANNING LTD.

# ***DIOCESE PROPERTY***

## **ARCHITECTURAL, MATERIALS & COLOUR CODES**

### ***Architect's Overview***

#### ***Architectural Codes***

The intent of the Architectural Codes is to develop an architectural character for the Diocese Property that is appropriate to the inner city neighbourhoods of Regina. The Codes are designed to encourage a range of variety and richness to develop with individual buildings, while creating an underlying order to the community.

When Codes are too restrictive, excessively limiting building form, colour, finish, or detailing, the result can be a monotonous community where all the buildings have the same character. If the Codes are not restrictive enough, there will exist no visual continuity of style within the community, or even on the elevations of each individual building. If styles that are unrelated to the vernacular of a city are imported into a community, the resultant building forms may appear alien and uncomfortable to the neighbourhood.

Through historical research and the photographic documentation of existing Regina neighborhoods, three predominant architectural styles have been identified – Tudor, Craftsman and Colonial, as being appropriate for the Diocese Property. Architectural Codes have been developed to define how to create good buildings in each style. The copyrighted Jenkins and Associates Architectural Codes encourage the development of unique buildings and diverse streetscapes, utilizing this style based “kit of parts” approach to Architectural Codes. The Kit of Parts approach allows for a virtually infinite number of combinations of building elements, materials, and building forms.

The Architectural Codes, in conjunction with the Colour and Material Codes, are intended to assist Homeowners and/or Builders in the design of all buildings in the Diocese Property. The Diocese Architectural Codes are unlike most design guidelines, as they are based on traditional architectural styles found in neighborhoods throughout Regina. The Codes are intended to lead to quick and conflict-free approvals by describing a wide range of specific details, materials, proportions and building elements that can be combined in a number of ways for Designers, Builders and Architects to use in the design of each building.

Building a great community is the best way to enhance and preserve economic values of real estate within a new community. If all the buildings are well designed within the framework of the Codes, the sum becomes much greater than the parts. Well-designed traditional buildings in well-designed communities have been shown empirically to retain 15-20% higher values than in unplanned communities.

### *Materials & Colours Codes*

The intent of the Materials & Colours Codes are to assist builders in identifying materials and colours suitable for each of the three historically based styles – Tudor, Craftsman and Colonial. The materials and colours are the result of research of the historical residential styles particular to Regina. It is the combination of the architectural style, and the appropriate materials and colours to that particular style, that will result in a historically accurate representation for the neighborhood of the Diocese Property.

Provided are Approved Colours and Materials to be used in conjunction with the Diocese Architectural Codes. The Material Specifications represent the quality of materials to be used in the Diocese Property. Paints and Materials of the same colour and quality, but produced by different manufacturers, may be substituted.

To ensure a diverse streetscape, houses of the same wall-cladding colour shall be separated by at least two other houses of different colours.

DIOCESE  
PROPERTY



ARCHITECTURAL  
CODES



GENERAL NOTES

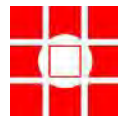

## 1.1 General

- 1.1.1 These codes have been established to provide a clear idea of the design intent for residential developments within the Diocese Property.
- 1.1.2 Every design proposal must be reviewed by the City of Regina, or their Consultant, to determine the appropriateness of the submission for the given site.
- 1.1.3 The City of Regina, or their Consultant, reserves the right to limit the repetition of details, materials, and colours between adjacent projects.
- 1.1.4 These codes shall apply to houses and their outbuildings, as well as townhouses and apartment buildings up to a maximum height of four storeys.
- 1.1.5 The requirements of the Diocese Property Architectural Codes exist in addition to the zoning requirements of the City of Regina Urban Planning Division and associated approvals that deal with such matters as building height restrictions and setbacks.

## 1.2 Elevations

- 1.2.1 Rules governing the composition of the front elevations shall be followed for each specific style.
- 1.2.2 Buildings occupying corner lots, or having elevations which face public spaces such as parks or pedestrian walkways, shall be considered to have two principal elevations. The flanking street or park elevation shall be composed and detailed with equal care and attention to detail to that of the front elevation.
- A building base is required on these elevations.
  - On side elevations, a box-out element or chimney is encouraged to end changes of materials.
- 1.2.3 Buildings on interior lots having elevations that face public spaces, such as parks:
- Shall be considered to have two principle elevations.
  - Rear elevations shall be composed and detailed with the same level of care and attention to detail as the front elevation.
  - Building bases are required on Front and Rear elevations.
- 1.2.4 Rear elevations on interior lots:
1. Rear elevations shall be executed in the same architectural style as the front elevation.
  2. Rules governing the composition of the rear elevation shall be followed for each specific style in accordance with the Architectural Codes; specifically noting the following:
    - Massing composition (roof and walls).
    - Alignment of elements.
    - Dormers and Bays.
    - Window proportions and alignment ( where possible).
    - Window types.
    - Window surrounds.
    - Decorative elements (shingles, trusses, brackets, battens, etc.).

© 1998, Jenkins & Associates Architecture and Town Planning Ltd.

Section

**G** General Notes (All Styles)

Drawing Name

**BUILDING FORM**

Drawing No.

**G1**



February 2007

## 1.2 Elevations - continued

3. Cantilevers are not permitted.
4. A building base is not required.
5. Variations between adjacent lots are required as per Codes.

### 1.2.5 Side elevations on interior lots:

1. Roof massing composition shall be consistent with the style of the front elevation.
2. Details on gables as per front and rear elevations are required (shingles, brackets, battens, etc.).
3. Window types as per Codes.
4. Window surrounds as per Codes.
5. Window proportion and alignment (where possible) as per Codes.

1.2.6 Townhouses of different styles shall have a change in roof line, and/or the front elevation must be stepped either forward or behind the front elevation of adjacent units.

1.2.7 Skylights are to be flat ONLY, and shall not be visible from the street.

1.2.8 Vent stacks, roof vents and other mechanical protrusions shall not be visible from the street.

1.2.9 Cantilevers are not permitted.

1.2.10 No two buildings on the same frontage shall have the same or substantially similar elevations within five lots of each other. See the sketch below.

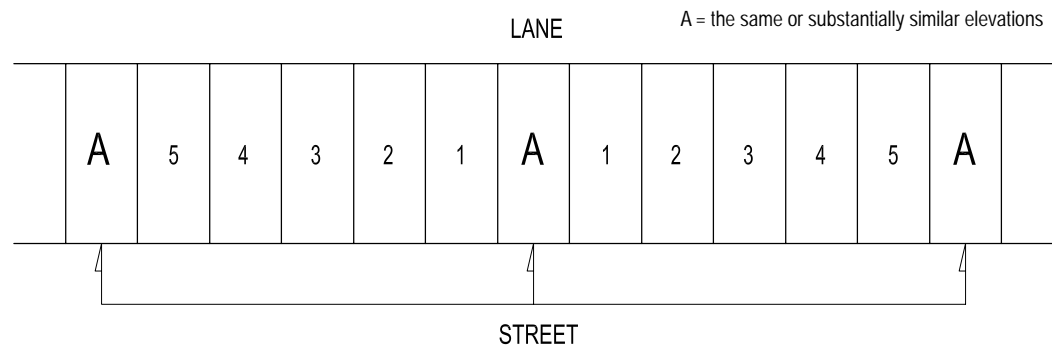

1.2.11 Buildings on the same frontage with the same wall cladding color must be separated from one another by a minimum of TWO lots.

1.2.12 Buildings with the exact same elevations, materials, and colour composition may not be on the same block, street frontage, or on the facing street frontage.

© 1998, Jenkins & Associates Architecture and Town Planning Ltd.

Section

**G** General Notes (All Styles)

Drawing Name

**BUILDING FORM**

Drawing No.

**G2**



February 2007

## 1.2 Elevations - continued

- 1.2.13 Buildings with the same or similar elevations on facing frontages must be separated by a minimum of 2 lots in both directions as shown in the sketch below.

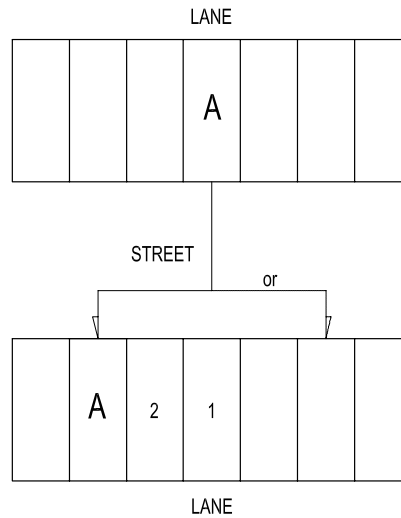

A = the same or substantially similar elevations

- 1.2.14 Brick or stone base material on the front elevation are to continue along the side elevations, ending at an inside corner of a projection, or wrap a MIN. 8'-0".

© 1998, Jenkins & Associates Architecture and Town Planning Ltd.

Section

G General Notes (All Styles)

Drawing Name

**BUILDING FORM**

Drawing No.

**G3**



February 2007

### 1.3 Wall Materials

- 1.3.1 STONE: approved local types and patterns of laying; approved local type and colours of grout.
- 1.3.2 BRICK: approved types, colours and local patterns of laying; approved local types and colours of grout.
- 1.3.3 STUCCO: cement or acrylic stucco; smooth or sprayed finish; textures finishes are NOT permitted.
- 1.3.4 Horizontal bevelled wood siding; painted or solid stained; 4" MAX. exposed. Approved horizontal wood fibre siding and fibre cement siding.
- 1.3.5 Panelled wood, painted, is suitable for bays, spandrels and base conditions.
- 1.3.6 Vinyl siding is NOT allowed.
- 1.3.7 Exposed foundation walls shall be clad in stone (real or simulated), brick, or smooth stucco (parging). On brick or stone clad buildings, the face of the foundation wall shall be built out a minimum of 2" beyond the face of the wall above and appropriately capped to emphasize the base of the building.
- 1.3.8 No wall material changes will be permitted to occur along vertical or diagonal lines except to differentiate towers, bay windows, and rear additions.
- 1.3.9 All elevations of the main body of the building shall be clad in the same material, or combinations of materials, similarly detailed. No changes in cladding are permitted on the rear and side elevations.
- 1.3.10 Gables on top of brick or stone walls may be finished in wood siding, wood shingles, brick, or stone depending on the style of the building. Stucco gables will be permitted in Craftsman and Tudor style houses.
- 1.3.11 Mortar colour is to accent the wall mass of masonry/stone construction.
- 1.3.12 Base materials and heights are specified for each style. A building base is used to visually ground the building.
- 1.3.13 When a building base is used on a front elevation, it must be continuous across the entire facade, except for porches clad in different material.
- 1.3.14 Base material or brick/stone clad front elevations are to wrap the side elevations ending at an inside corner of a projection, or wrap a MIN. 2.5 m .

### 1.4 Roof Materials

- 1.4.1 Smooth sawn wood shingles, not split shakes.
- 1.4.2 Natural slate.
- 1.4.3 Natural standing seam copper or zinc.
- 1.4.4 Flat profile ("slate") concrete tiles, approved colours only.
- 1.4.5 Asphalt shingles, approved colours only.
- 1.4.6 Vent stacks, roof vents, and other mechanical protrusions shall be painted the colour of the roof.

© 1998, Jenkins & Associates Architecture and Town Planning Ltd.

Section

**G** General Notes (All Styles)

Drawing Name

**BUILDING FORM**

Drawing No.

**G4**



February 2007



## 2.1 Bays

- 2.1.1 May extend 6' MAX. beyond the outside front face of the building and may be 8' MAX. in width if on the front elevation, 12' MAX. if on the side elevations.
- 2.1.2 Main floor bays may not be visibly cantilever on front elevations and must extend completely to grade; second floor bays must be supported by brackets, located above a porch, or as otherwise indicated in each Style Guideline.
- 2.1.3 Bays must project a minimum of 18" from the main wall of the building.

## 2.2 Porches and Stoops

- A. **SMALL PORCH:** A small, highly detailed porch which highlights only the front entry; shall have a min. area of 25 sq.ft.; may have a hipped, gabled, barrel, or flat top roof if the flat roof is accessible as a balcony; roof types are dependant on the specific style.
- B. **PORCH ACROSS ENTIRE FRONT FACADE:** Extends the full width of main body of the building.
- C. **L-PLAN PORCH (Cross Gable):** This porch type is where its roof shall be set back 3' MIN. from the face of a front facing gable.
- D. **SIDE PORCH, SIDE ENTRY CONDITIONS ONLY:** On lots having a 6' sideyard setback and greater, a porch may extend down the side of the building to access an entry located on that side. Side porches may not encroach into the sideyard setback EXCEPT on corner lots.

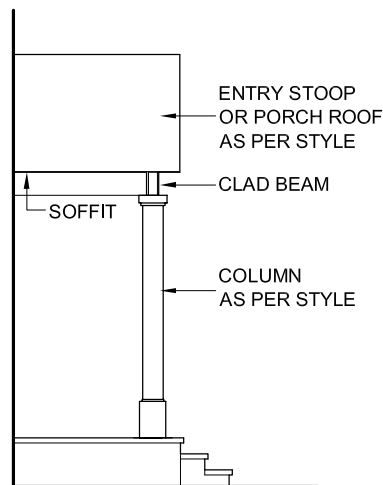

© 1998, Jenkins & Associates Architecture and Town Planning Ltd.

Section

G General Notes (All Styles)

Drawing Name

II. BUILDING ELEMENTS

Drawing No.

G5



February 2007

## 2.2 Porches and Stoops - continued

- 2.2.1 The smallest usable porch depth dimension shall be 5' MIN., 6' is encouraged.
- 2.2.2 All porches must be detailed to include an entablature above columns. The Entablature (beam and fascia) is to continue on all exposed sides of the porch. See specifics under each style.
- 2.2.3 Pilasters are required at the intersections of the porch entablature and the main wall of the building.
- 2.2.4 Porch steps shall be detailed in the same material as the porch itself.
- 2.2.5 Where wood floors on porches are used, steps shall have closed risers and cut stringers with overhanging treads.
- 2.2.6 Porches may be left open, or may be enclosed by screened or glazed sections. If enclosed, it must be detailed carefully as a columned porch with infill screen or glazing panels to match the windows of the building.
- 2.2.7 Prefabricated concrete stoops are encouraged to be faced in brick, stone or coloured concrete to match the buildings base material.
- 2.2.8 Stoops may be roofed by a canopy supported by brackets, cables, or chains; the design of the canopy and its support system must be in keeping with the architecture of the building.
- 2.2.9 Commercial styled metal/fabric awnings are not permitted.
- 2.2.10 Porches and decks visible from the street shall be skirted in the same material as the building base (concrete parging is NOT acceptable); or skirting shall be wood lattice, horizontal bevelled wood siding, panelled wood, wood shingles (when used on plinths), brick or stone. Vinyl siding is NOT permitted.
- 2.2.11 When the porch and skirting is of wood, panelled wood detailing shall be used below columns. This creates visual base on which the column stands.
- 2.2.12 Decks shall use the same Balustrades and Railing styles as the front porch.

© 1998, Jenkins & Associates Architecture and Town Planning Ltd.

Section

**G** General Notes (All Styles)

Drawing Name

**II. BUILDING ELEMENTS**

Drawing No.

**G6**



February 2007

## 2.3 Windows and Doors

- 2.3.1 Proportions of allowable front facade glazing is specific to each Style.
- 2.3.2 All windows are to have a vertical proportion, although they may be composed of square sections.
- 2.3.3 Casement, double-hung, and single hung are appropriate window types; accompanying non-opening windows must match the profile and detail of the adjacent windows.
- 2.3.4 No window facing the street shall have a sill height greater than 2'-8" above the floor of its respective room (excluding kitchen windows, "special shape dormers).
- 2.3.5 Windows shall be built of wood; and are to be painted, stained, or clad. Some vinyl window styles may be permitted.
- 2.3.6 Use of figured or frosted glass is NOT permitted.
- 2.3.7 Tinted glazing is not permitted in windows facing the street; except approved stained glass.
- 2.3.8 Muntin bars shall be of the same material and finish as the window sash and frame, and may occur on the outside of the glass only, or on both the inside and outside of the window.
- 2.3.9 All window lites created by muntins are to be square or vertically rectangular in proportion, including transoms.
- 2.3.10 Feature windows (ie. circular, elliptical, octagonal, gothic) may be used only ONCE on the front elevation of each unit. Locations for these windows are specific to each Style.
- 2.3.11 Shutters may be used, specific to each Style. Fully operational shutters are strongly encouraged. If shutters are decorative only, they must appear in the exact same proportions as if they were operational. Shutters are to be used consistently on all windows of the street elevation, except for feature windows.
- 2.3.12 Shutter styles shall be submitted for approval. Shutters are encouraged to be of wood.
- 2.3.13 Double front entry doors are not permitted. Single front entry doors with or without transoms and/or sidelights are permitted ONLY.
- 2.3.14 Main entry doors shall have glass panels, glass sidelights, or both.
- 2.3.15 Metal sliding patio doors are NOT permitted on elevations visible from the street.
- 2.3.16 Screen doors shall be fully screened and without decorative trim; they shall be finished to match the door style they serve.
- 2.3.17 Garage doors facing a street shall be traditional style garage doors with vertically proportioned panels and glazing.

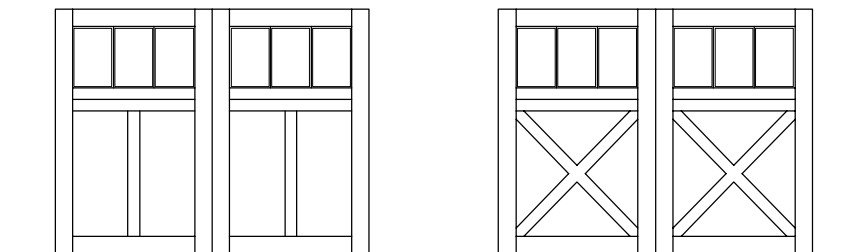

TRADITIONAL GARAGE DOORS

© 1998, Jenkins & Associates Architecture and Town Planning Ltd.

Section

G General Notes (All Styles)

Drawing Name

II. BUILDING ELEMENTS

Drawing No.

G7



February 2007

## 2.3 Windows and Doors - continued

- 2.3.18 Garage doors shall not exceed 8' in height and 16' in width if facing the street.
- 2.3.19 Glass block may be used on side elevations of buildings not facing a street when fire code restrictions apply. The proportions of the glass block opening are to be vertically rectangular or square. NO stepped patterns will be permitted.

## 2.4 Chimneys

- 2.4.1 Chimneys as features on exterior walls are encouraged. A built-out fireplace "bay" will not be permitted unless appears as a traditional chimney form.
- 2.4.2 Chimneys must be brick or stone if the building is clad in brick or stone.
- 2.4.3 Chimneys may be brick, stone, or smooth stucco if the building is clad in wood siding or stucco.
- 2.4.4 Chimneys may be vinyl with appropriate trim boards, only if the building is clad in vinyl. Vinyl clad chimneys are not permitted on front elevations.
- 2.4.5 Chimneys on exterior walls shall have a minimum horizontal cross sectional area of 12 sq.ft. at the base of the chimney.
- 2.4.6 Visible cantilevers are NOT permitted; chimneys must extend completely to grade, or any cantilevered portion must be concealed. ( ie. by a porch)
- 2.4.7 Vent stacks are not to be visible from the street.
- 2.4.8 Flashing on chimneys should match the colours of the capping used on the chimney.

© 1998, Jenkins & Associates Architecture and Town Planning Ltd.

Section

**G** General Notes (All Styles)

Drawing Name

**II. BUILDING ELEMENTS**

Drawing No.

**G8**



February 2007

## 2.5 Columns

- 2.5.1 Column proportions and styles shall conform to the standards set out in each Architectural Style.
- 2.5.2 Half-columns ( round columns cut in half and placed against a wall) are NOT permitted.
- 2.5.3 The use of pilasters (shallow pier or rectangular columns projecting only slightly from a wall) or buttresses are specific to each style, and are not to be confused with half columns.
- A. CLASSICAL:                      -fluted or unfluted;  
  -Doric, Ionic, Tuscan styles;  
  -Double Doric, Double Ionic, Double Tuscan;  
  -Proportions according to classical principals (1:8 width:height)
- B. VERNACULAR                      -wood post, 6" MIN. square, corners chamfered, slightly grouped;  
  -built-up, tapered wood columns, 8" MIN. square (as per local examples);  
  -brick or stone (real or approved simulated) , continuous all sides.
- C. COMPOSITE                      -brick, stone, or shingle clad plinth with:  
  -classical columns above, singly or grouped (most common);  
  -wood posts, or wood columns above (as per local examples);  
  -the plinth shall match the height of the porch balustrade.

## 2.6 Balustrades

- 2.6.1 Where the porch is less that 2' above grade, balustrades shall function as a sitting rail, 18" min -24" max. in height above the floor of the porch.
- 2.6.2 Sitting rails shall be 6" MIN. - 12' MAX. in depth. Balusters shall adjust to this required width.
- 2.6.3 May be wood, painted steel, or wrought iron. Vinyl will NOT be accepted.
- 2.6.4 Must be consistent in the design and materials with the architecture of the building.
- 2.6.5 Wood balustrades must have corner newel posts of 6" MIN. diameter/width when there are no columns at the corners.
- 2.6.6 Intermediate newel posts are required in balustrade lengths greater than 8'.
- 2.6.7 Newel posts are required where there is a turn (or corner) in the balustrade, and there is no column.
- 2.6.8 Newel posts shall be detailed similarly to the columns used. The skirting of the porch shall be detailed below the newel post the same as below the column.
- 2.6.9 Balusters shall be spaced to meet National Building Code minimum requirements.
- 2.6.10 May be solid shingled, sided, or bricked to handrail height to match the base in Tudor and Craftsman styles.
- 2.6.11 Wood balustrades shall have 2" X 2" wood spindles.
- 2.6.12 Metal balustrades shall have 3/4" dia. verticals MIN.

© 1998, Jenkins & Associates Architecture and Town Planning Ltd.

Section

G General Notes (All Styles)

Drawing Name

II. BUILDING ELEMENTS

Drawing No.

G9



February 2007

## 2.7 Soffits and Trim

- 2.7.1 Trim shall be finished in wood ONLY on all Styles, stained or painted (see Material Codes for approved substitutes for wood). Trim shall include simple door and window surrounds, cornices and sills; corner-boards and horizontal batons; detailing; bargeboard; top trim plates on plinths.
- 2.7.2 Soffits shall be wood, pre-manufactured wood, or approved vinyl beadboard on the underside of porches or stoops. Aluminum is permitted on all other soffits.
- 2.7.3 Fascia shall be of wood, or approved aluminum. Vinyl fascia is not permitted.
- 2.7.4 Trim shall be 4" MIN. - 10" MAX. around all windows and doors.
- 2.7.5 Corner boards to be 4" MIN. - 10" MAX. Corner boards are to be wider than or equal to the profile of the siding.
- 2.7.6 Horizontal material changes shall be separated by 4" MIN. trim boards; in cases of brick or stone used below other materials; the brick or stone shall be topped by a brick, stone, or pre-cast concrete coping.
- 2.7.7 No stucco trim or raised stucco detailing of any kind will be permitted.
- 2.7.8 Bargeboard shall be 8" MIN in depth.
- 2.7.9 Cornice mouldings or trim boards shall always be used where a wall meets the underside of an eave.
- 2.7.10 Dentil block, or other similar trim detailing, shall be used ONLY with the cornice moulding.
- 2.7.11 Eavestrough and downpipes are to be minimized on front elevations, and are to be arranged symmetrically; ptd. to match trim. Flashings are to be minimized on front elevations, and to be painted to match trim.
- 2.7.12 Duplexes having non-symmetrical facade must be separated visually with 8" MIN. batten board, or downpipe.
- 2.7.13 Trim and batten boards must have a thickness 1/2" greater than adjacent wall cladding.
- 2.7.14 Manufactured wood or wood soffit ventilation strips are to be linear.
- 2.7.15 Trim is required around all openings, on all elevations.
- 2.7.16 On side and rear elevations with gabled roofs, a horizontal trim board is required to separate the gable from the main wall. This trim typically ties into the soffit trim of the adjacent elevations. The horizontal trim is not required on buildings with stone gables.

© 1998, Jenkins & Associates Architecture and Town Planning Ltd.

Section

**G** General Notes (All Styles)

Drawing Name

**BUILDING FORM**

Drawing No.

**G10**



February 2007

### 3.1 General

- 3.1.1 Outbuildings, such as detached garages, shall be consistent in design and materials with the main building.
- 3.1.2 Roof pitch, windows, doors and trim details of outbuildings shall match those of main building.
- 3.1.3 Flat roofs will only be permitted on buildings in cases where the main building has a flat roof.
- 3.1.4 Outbuildings occupying corner lots shall be considered to have two principal elevations (lane and flanking the street) .
- 3.1.5 Outbuildings shall be separated from the main building by a distance of 8' MIN.
- 3.1.6 Connection to the main building may only occur in the form of an open breezeway or inclosed link, the eave height of either not exceeding one storey.
- 3.1.7 The roof of any outbuilding shall be separated and differentiated from both the roof of the link and the roof of the main house.
- 3.1.8 Front drive garages are NOT allowed, except where rear access is not possible.
- 3.1.9 On lots with two frontages the garage doors shall be turned 90 degrees from the street.
- 3.1.10 Where front drive garages are allowed, and where the dimensions of the site are adequate (55' min. lot width), garage doors must be turned 90 degrees from the street.
- 3.1.11 Where front drive garages are allowed on narrow lots:
- The garage should be incorporated into the form of the house.
  - The wall of the garage door may not extend more than 6' -6" beyond the front wall of the house (does not include the porch).
  - Paired single door garages are encouraged.
  - Garage should not be located adjacent to a flanking road or a regional pathway wherever possible.
  - A window is required on at least on side of the garage; window detail is to be consistent with the design guidelines for the main building.
  - To minimize the impact of monotonous row of driveways, surface materials should alternate between adjacent lots.
- 3.1.12 The same style of garage doors shall NOT be used on adjacent lots for both front and rear drive garages.

© 1998, Jenkins & Associates Architecture and Town Planning Ltd.

Section

**G** General Notes (All Styles)

Drawing Name

**III. OUTBUILDINGS**

Drawing No.

**G11**



February 2007

## 4.1 Fencing & Retaining Walls

- 4.1.1 Chain link fencing will not be permitted except for discrete enclosures within property lines (ie. dog runs, pool enclosures) as long as they are not visible from a street or lane.
- 4.1.2 Hedging, brick, stone, wrought iron, and picket fencing will be permitted.
- 4.1.3 In addition to the materials listed above, picket fencing will be permitted on detached single family lots.
- 4.1.4 In a front yard, side or rear yard flanking a street or public space (park, walkway), retaining walls must be clad in brick, stone, or simulated stone, and have a finished cap. The cap must be pre-cast concrete or to match the retaining wall material. Where the height of the retaining wall is less than 2'-0" above grade, the wall may be concrete.

© 1998, Jenkins & Associates Architecture and Town Planning Ltd.

Section

**G** General Notes (All Styles)

Drawing Name

**IV. LANDSCAPING**

Drawing No.

**G12**



February 2007



# DIOCESE PROPERTY



# ARCHITECTURAL CODES

1

# TUDOR STYLE



## *Tudor Style Precedents*

Provided is a selection of photographic examples of buildings in the Tudor style. The Tudor style is reflected in many of the features of the existing heritage buildings located on the Diocese site, and should serve as a strong guiding influence for new development.

Tudor style is characterized by steeply pitched roofs, with side-gabled facades dominated by one or more prominent cross gables. The gable ends are typically finished with decorative half-timbering with stucco. Brick and stone are also found in gable ends of Tudor style, but half-timbering is the prevailing feature.

Windows are tall, narrow and often ganged in multiple groups. The windows are typically double hung with multi-pane glazing. The front doors are often identified on the front elevation by simple arches, or stone detailing creating a quoin surround. Stone trim is very common around windows and doors.

Large, elaborate chimneys are placed in prominent locations on front or side elevations. The chimneys are usually constructed of stone or brick with complex patterns. It is common to also see stone or brick used on the main body of the house.

Tudor style buildings are usually darker in appearance. The roof and trim colours are typically brown or black. Stone or brick are also usually darker in colour. The stucco on Tudor facades is usually light in colour to contrast with the dark half-timbering and trim.



Bishop's Court



**Tudor style townhouses.**

**Multiple front gables are common.**

**Stone or brick is commonly used on the main body of the house.**



**Asymmetrical massing is a characteristic feature of the Tudor style.**

**Gable ends typically finished with decorative half-timbering.**

© 1998, Jenkins & Associates Architecture and Town Planning Ltd.

Section

I. Building Form

Drawing Name

**HOUSE PRECEDENTS**

Drawing No.

**1.01**

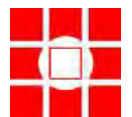

February 2007



**Front façade dominated by one or more prominent cross gables, usually steeply pitched.**

**Bays with half-timbering are common to Tudor style.**



**Gable ends typically finished with decorative half-timbering.**

© 1998, Jenkins & Associates Architecture and Town Planning Ltd.

Section

**I. Building Form**

Drawing Name

**HOUSE PRECEDENTS**

Drawing No.

**1.02**

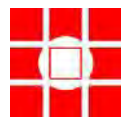

February 2007



**Steeply pitched roof, usually side-gabled (less commonly hipped or front-gabled).**

**Tall, narrow windows, commonly in multiple groups, and with multi-pane glazing.**



**Chimneys are usually prominent features.**

© 1998, Jenkins & Associates Architecture and Town Planning Ltd.

Section

I. Building Form

Drawing Name

HOUSE PRECEDENTS

Drawing No.

1.03



February 2007



A picturesque roof line is created by the asymmetrical arrangement of towers, chimneys and dormers.

The entrance is marked by a prominent pointed arch with a stone surround.



Massive chimneys are typical, and may be crowned by decorative chimney pots.

© 1998, Jenkins & Associates Architecture and Town Planning Ltd.

Section

I. Building Form

Drawing Name

HOUSE PRECEDENTS

Drawing No.

1.04



February 2007

**FRONT GABLE**  
Symmetrical

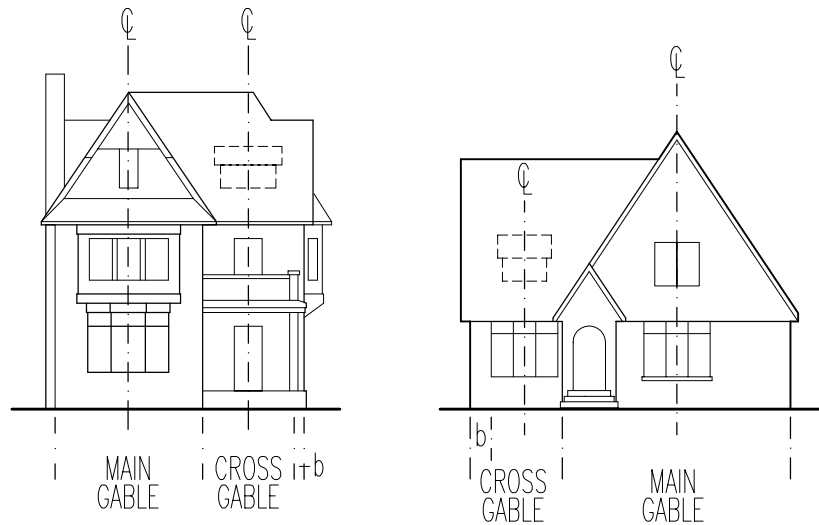

$b = 12''$  MIN.

1. Bays, ganged windows, and feature windows shall always be centered in the main gable.
2. Windows in the main gable shall always be placed in groupings (gangs) of three or more on the main floor.
3. Entry doors and porches shall be centered in the cross gable or entry gable.
4. Windows placed on the main floor in the cross gable shall be grouped.
5. Entry doors are feature elements of Tudor style, and are typically located asymmetrically on the front elevation.

© 1998, Jenkins & Associates Architecture and Town Planning Ltd.

Section

I. Building Form

Drawing Name

**STREET ELEVATION 1**

Drawing No.

**1.05**



February 2007

**FRONT GABLE**  
**Asymmetrical**

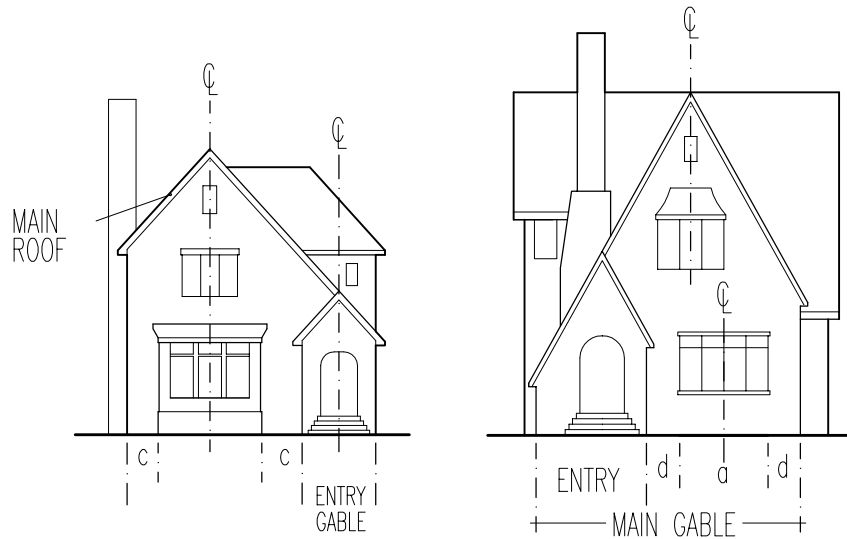

1. Upper floor windows, bays and feature windows shall be centered under the apex of the roof of the main gable.
2. Main floor windows in the main gable shall always be placed in groupings (gangs) of three or more.
3. Doors and entry features shall be centered below the apex of the entry gable.

© 1998, Jenkins & Associates Architecture and Town Planning Ltd.

Section

I. Building Form

Drawing Name

**STREET ELEVATION 2**

Drawing No.

**1.06**

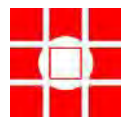

February 2007



**NARROW LOT OR MULTI-FAMILY  
FRONT GABLE**



1. Bays, ganged windows, and feature windows shall always be centered in the main gable.
2. Windows in the main gable shall always be placed in groupings (gangs) of 3 or more on the main floor.

**APARTMENT BUILDINGS**



1. Asymmetrical massing and variations in roof heights are typical of the style.
2. Bays, ganged windows, and feature windows shall always be symmetrically arranged within a gabled bay.
3. Windows on the main floor shall always be placed in groupings (gangs) of 3 or more.
4. Variations in gable size and style between neighboring bays is allowed. Roof pitch shall always remain consistent.

© 1998, Jenkins & Associates Architecture and Town Planning Ltd.

Section

**I. Building Form**

Drawing Name

**STREET ELEVATION 3**

Drawing No.

**1.07**

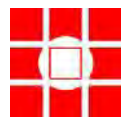

February 2007

## STREET ELEVATION NOTES

1. MATERIALS: Main House
  - brick, stone, smooth or sprayed stucco.
  - Typically, materials are consistent on all elevations of the main body of the house, except material changes for gable ends and bases.
2. MATERIALS: Sidewings
  - to be panelled wood and detailed as a 'porch' with infill panels.
3. MATERIALS: Rearwings
  - may be wood siding if the main body of the house is in brick or stone.
4. MATERIALS: Building Base
  - stone, simulated stone, or brick, w/ smooth stucco or cedar shingles above.
  - smooth stucco w/ half timbering above.
  - base min. height - foundation wall to max. - underside of first floor windows.
5. Additions to the basic building are to be in the form of sidewings or rearwings. These additions are to be less than the main body of the house both in width and height.
6. HALF TIMBERING: is a common detail on the Tudor house, typically consisting of stucco infill panels between timber/wood patterning. This infill may also be brick layed in pattern.
7. Half timbering shall NOT be used on houses with parapeted gable ends. Typically, materials used on the main floor are carried into the gable parapet wall.
8. Half timbering is encouraged to be used above the main floor, most typically always appearing in main gables, including dormers, of the elevation.
9. Bays and ganged windows are interchangeable. Elevations may be composed with bays, or may be absent from the elevation in lieu of ganged windows. Both conditions are typical.
10. Ganged windows at the main floor usually are found in groupings of 3 - 5 windows.
11. Ganged windows at the second floor usually are found in groupings of 2 - 3 windows.

© 1998, Jenkins & Associates Architecture and Town Planning Ltd.

Section

I. Building Form

Drawing Name

STREET ELEVATION 4

Drawing No.

1.08



February 2007

## MAIN ROOF TYPES

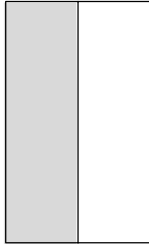

A. FRONT GABLE

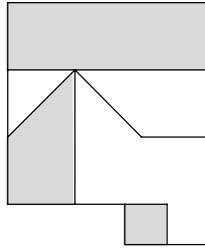

E. OVERLAPPED GABLES

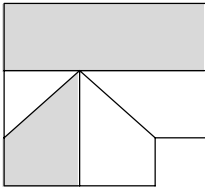

B. CROSS GABLE (Most Common)

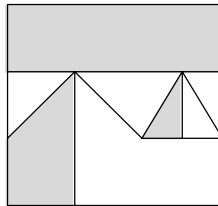

E. MULTIPLE FRONT GABLES

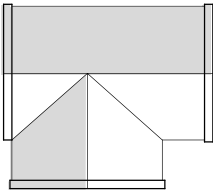

C. CROSS GABLE w/ PARAPETED GABLE ENDS

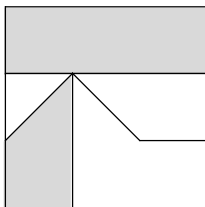

D. ASYMMETRICAL FRONT GABLE

1. **MATERIALS:**
  - wood shingles, NOT split shakes.
  - flat profile ("slate") concrete tiles; approved profiles and colours ONLY.
  - natural slate, copper, zinc.
  - asphalt shingles; approved styles and colours only.
2. **SLOPE:**
  - 12:12 MIN.; steeper pitches are encouraged.
3. The eave shall overhang 6" MIN. - 12" MAX.
4. The eave shall overhang 6" MIN. - 12" MAX. on gable ends.
5. Parapeted gable ends are permitted on any roof configuration.
6. If used, parapeted gable ends must be used on all roof and dormer gable ends.
7. Parapet walls shall extend 8" MIN. - 12" MAX. above the roof.
8. Parapet walls shall be 8" MIN. - 12" MAX. when visible from the street.
9. The fascia board shall be 6" MIN. - 12" MAX.
10. Exposed rafter ends are NOT common on this style, but will be permitted with prior approval.
11. Bargeboard on gable ends shall be 4" MIN. - 12" MAX.

© 1998, Jenkins & Associates Architecture and Town Planning Ltd.

Section

## II. Building Form

Drawing Name

# ROOFS

Drawing No.

# 1.09



February 2007

## ENTRY PORCH

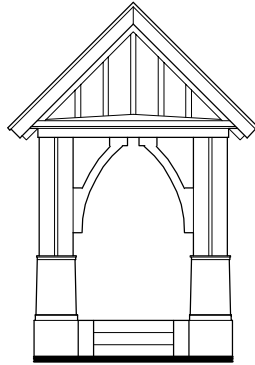
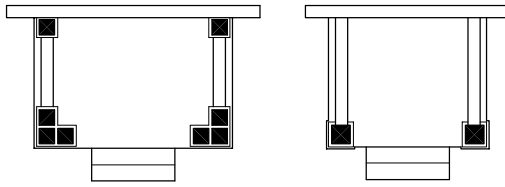

Gabled

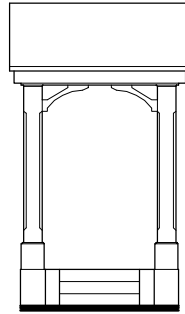

Shed

## FRONT PORCH

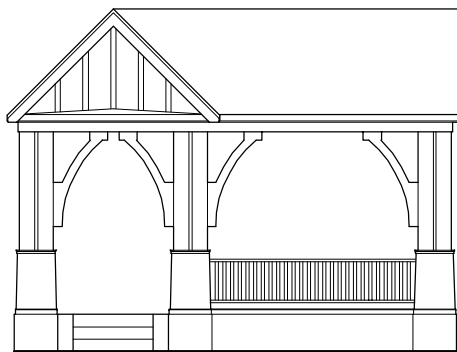
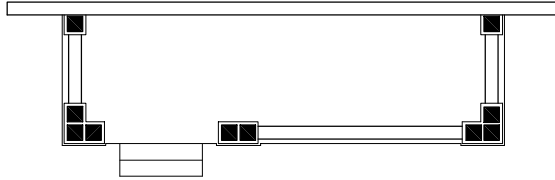

w/ Entry Gable (Typical)

1. **MATERIALS: Porch Floors**  
- concrete faced in brick or stone is encouraged.  
- wood.
2. **MATERIALS: Roofs, Columns, Balustrades**  
- as specified in respective sections
3. **MATERIALS: Gable Ends**  
- panelled exterior plywood.  
- decorative wood shingles.  
- wood shingles.  
- smooth stucco.  
- smooth stucco with smooth / rough sawn timber detailing.
4. Porches are to be one-storey to the eave MAX.
5. Roof slopes, overhangs and fascia detailing as specified in ROOFS.
6. Porches may combine wood and stone detailing.
7. GABLE END detailing on porches shall be consistent in theme as elsewhere on the house.
8. Exposed rafters are encouraged above porches.
9. Steps to porches are encouraged to be concrete faced in brick or stone.
10. Porches which extend across the entire front elevation are not common in this style. Front porches shall be located beside extended front gables.

ex.

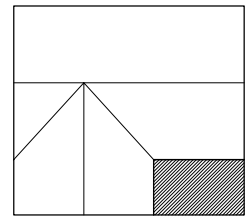

11. All porches are to have wooden brackets or stucco arches.
12. Knee braces are encouraged under all bays on elevations facing a street or public space.
13. Min. 2x4 material to be used on bracket and brace construction.
14. Beam and fascia together to measure 8" min.

© 1998, Jenkins & Associates Architecture and Town Planning Ltd.

Section

## II. Building Elements

Drawing Name

# PORCHES

Drawing No.

# 1.10



February 2007

TRADITIONAL EXAMPLES

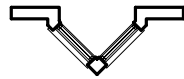
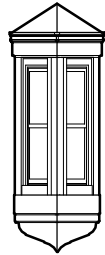

A.  
TRIANGULAR  
ORIEL

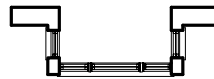
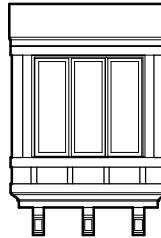

B.  
BRACKETED  
SQUARE BAY

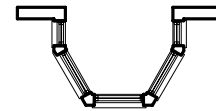
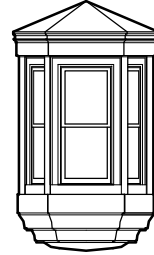

C  
FACETED  
ORIEL

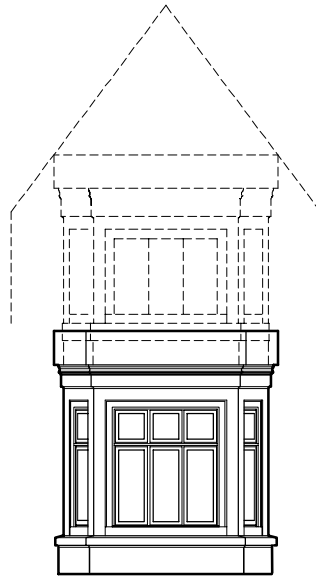
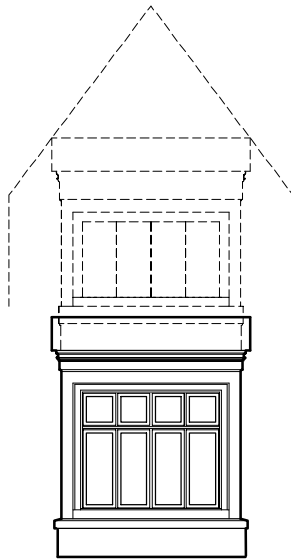

D.  
SQUARE BAY



E.  
FACETED BAY

1. MATERIALS: Roofs  
- shall be the same as indicated in ROOFS.
2. MATERIALS: Base  
- shall be the same as the main body of the house.
3. MATERIALS: Body  
- the main body of the bay shall be panelled wood. See Materials Code for approved alternatives for wood.
4. Cantilevered bays are permitted above the main floor, and shall be supported by brackets.
5. Bays are typically viewed as a feature element and are to be located under a main gable end.
6. Oriels do not require support by brackets.
7. The wall between the end of a bay and the nearest window of the bay shall be 12" MIN.
8. Single storey bays are also common in this style.

© 1998, Jenkins & Associates Architecture and Town Planning Ltd.

Section

II. Building Elements

Drawing Name

BAYS

Drawing No.

1.11



February 2007

## WINDOW PROPORTIONS

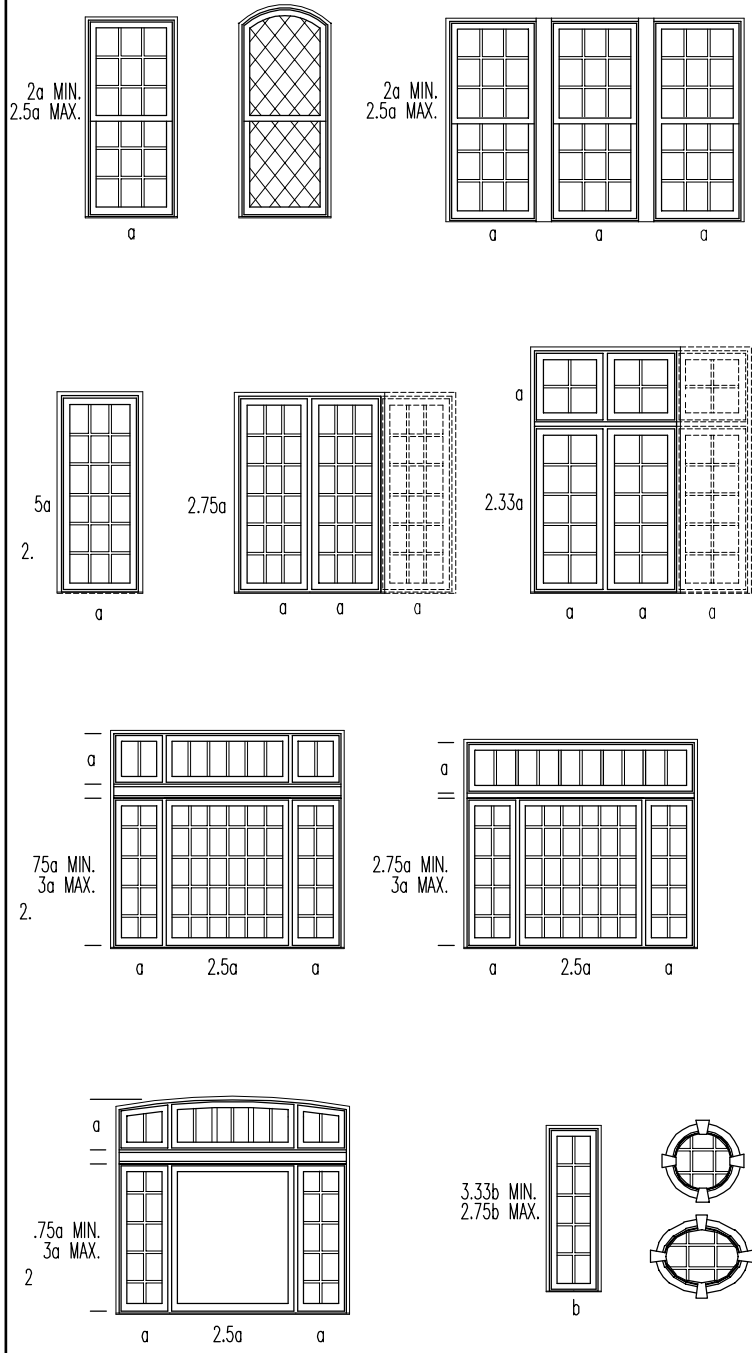

## FEATURE WINDOWS

1. **MATERIALS: Windows**  
 - shall of wood; painted, stained or clad.  
 - some vinyl styles with prior approval.
2. Upper floor windows are to have a proportion of:  
 $2a : a$  ONLY.
3. Main floor windows are to have a proportion of:  
 $2a : a$  TO  $2.5a : a$
4. Windows in gangs of three are common, and are permitted on all floors.
5. Transoms are permitted on all windows.
6. Windows with brick, stone, or precast conc. cornice and trim details may be used on stone/brick houses ONLY.
7. Windows with Gothic Drip mould may be used on both stone/brick and wood/stucco houses.
8. Windows in gangs of three or more are typical at the main floor below main gable ends.
9. Muntin bars are to be 1" MIN. in thickness.
10. Muntin bars are encouraged to be placed on the outside and inside of window glazing, however, muntin bars may be placed inside sealed units or, at a MIN., on the outside of window glazing.
11. **MATERIALS: Muntin Bars**  
 - wood; painted, stained or clad  
 - some vinyl styles with prior approval only.
12. Full grilles of muntin bars are encouraged on all windows.

© 1998, Jenkins & Associates Architecture and Town Planning Ltd.

Section  
**II. Building Elements**  
 Drawing Name  
**WINDOW TYPES**

Drawing No.  
**1.12**

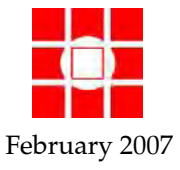

## WINDOW SURROUNDS EXAMPLES

*On Stone/Masonry Buildings*

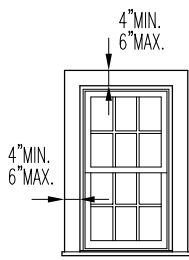

A.  
WOOD TRIM

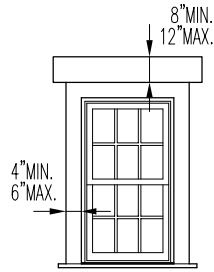

B.  
STONE/TIMBER  
LINTEL

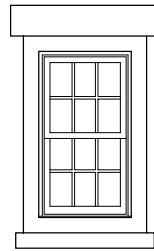

C.  
STONE/TIMBER  
CORNICHE AND SILL

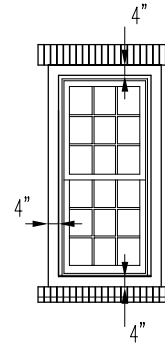

D.  
BRICK  
CORNICHE AND SILL

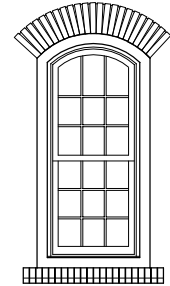

E.  
ARCHED BRICK  
CORNICHE AND SILL

*On Wood/Stucco Buildings*

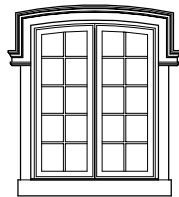

F.  
WOOD TRIM w/  
GOTHIC DRIP MOULD

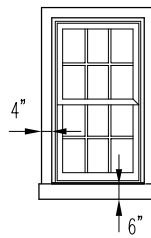

G  
WOOD TRIM  
and SILL

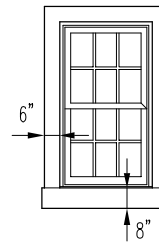

1. MATERIALS: Surrounds
  - shall of wood; painted or stained.
  - rough or smooth sawn timber.
  - Smart Trim.
  - stone, brick, pre-cast concrete.
  - approved pre-manufactured cast/mouldings.
2. Shutters are not permitted in this style.

© 1998, Jenkins & Associates Architecture and Town Planning Ltd.

Section

II. Building Elements

Drawing Name

WINDOW SURROUNDS

Drawing No.

1.13



February 2007

## DOOR TYPES

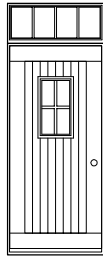

RECTANGULAR  
TRANSOM

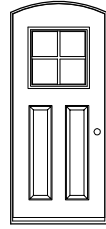

SPRUNG  
DOOR ARCH

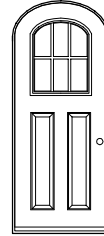

GOTHIC  
DOOR ARCH

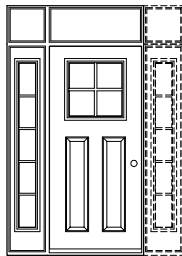

RECT. TRANSOM  
w/ SIDELIGHTS

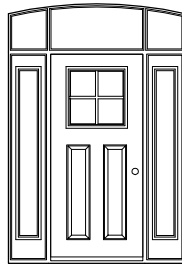

SPRUNG TRANSOM  
w/ SIDELIGHTS

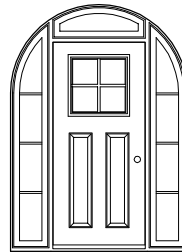

ARCHED TRANSOM  
& SIDELIGHTS

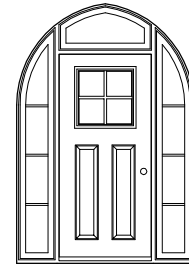

GOTHIC ARCH  
TRANSOM & SIDELIGHTS

1. **MATERIALS: Doors**
  - shall be wood; painted, stained, or clad.
  - insulated metal doors.
2. Door panel configurations may vary from those shown above.
3. Single sidelight, single sidelight with transom, are permitted on asymmetrically organized elevations ONLY.
4. Double sidelights, double sidelight with transom, are permitted on symmetrically organized elevations ONLY.
5. Arched transoms and sidelights must be used in symmetrical sidelight and door configurations ONLY.
6. Symmetrical sidelight and door configurations are to be used on larger houses (40'+) ONLY.

© 1998, Jenkins & Associates Architecture and Town Planning Ltd.

Section

### III. DETAILS

Drawing Name

## DOOR TYPES

Drawing No.

# 1.14



February 2007



## TRADITIONAL DOOR SURROUND EXAMPLES

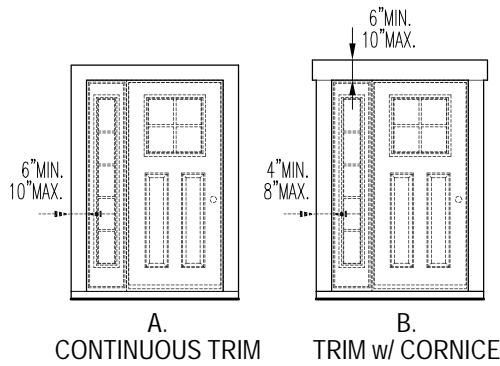

1. MATERIALS: Surrounds
  - shall of wood; painted, stained or clad.
  - rough/smooth sawn timber.
  - Smart Trim.
  - stone, brick, pre-cast concrete.
2. In this style, doors are typically recessed from the surround. Doors may be recessed 8" MIN. - 36" MAX.

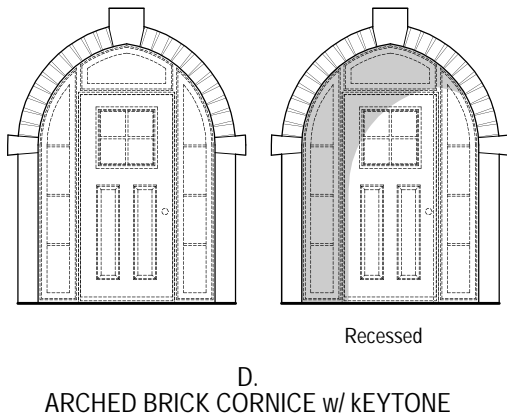
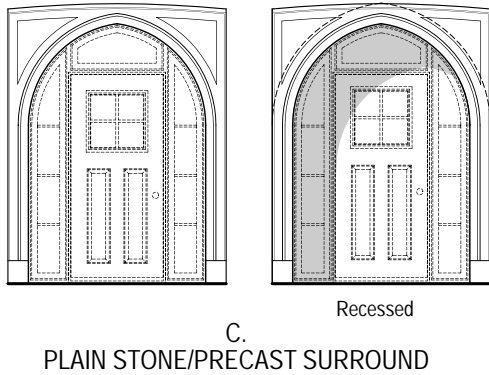

© 1998, Jenkins & Associates Architecture and Town Planning Ltd.

Section

### II. DETAILS

Drawing Name

# DOOR SURROUNDS

Drawing No.

# 1.15

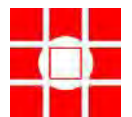

February 2007

## DORMER WINDOW PROPORTIONS

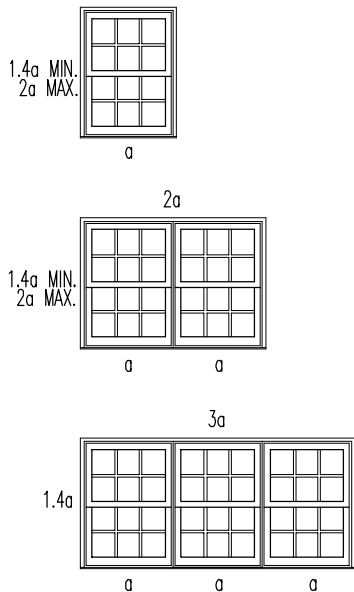

1. MATERIALS and NOTES as outlined for WINDOWS shall apply to all DORMERS.

2. MATERIALS: Front and Sides  
 - panelled exterior plywood.  
 - decorative wood shingles.  
 - rough sawn wood shingles.  
 - smooth stucco.  
 - brick, stone (parapetted gable dormers ONLY).

3. SLOPE:  
 - GABLED: the roof slope shall be the same as the MAIN ROOF.  
 - SHED: 4:12 MIN.

4. Eave details shall be the same as the MAIN ROOF.

5. The fascia board shall be 12" MAX.

6. Exposed rafter ends shall be used when they are used on the MAIN ROOF.

7. SHED dormers shall have ganged windows ONLY.

8. Parapetted gables shall ONLY be used when they are used elsewhere on the building.

9. Parapet walls shall extend 8" above the roof of the dormer.

## TRADITIONAL DORMER EXAMPLES

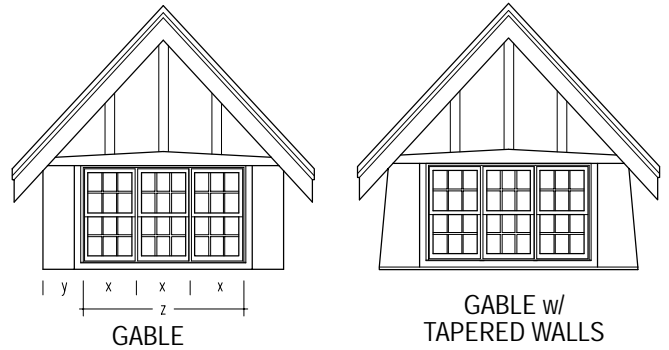

GABLE

GABLE w/  
TAPERED WALLS

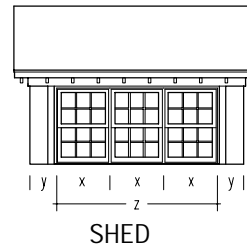

SHED



HIPPED w/  
TAPERED WALLS

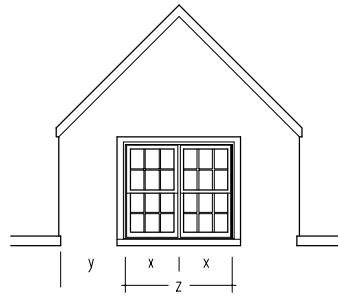

PARAPETTED GABLE



EYEBROW

10. Parapet walls on dormers shall be 10" thick.

11. Ganged windows are encouraged on GABLED dormers.

12. Gable end detailing in dormers shall conform to GABLE ENDS.

13. The wall between the end of a dormer and the nearest window (y) shall be 12" MIN.

© 1998, Jenkins & Associates Architecture and Town Planning Ltd.

Section

Building Elements

Drawing Name

DORMERS

Drawing No.

1.16



February 2007

## TRADITIONAL COLUMN EXAMPLES

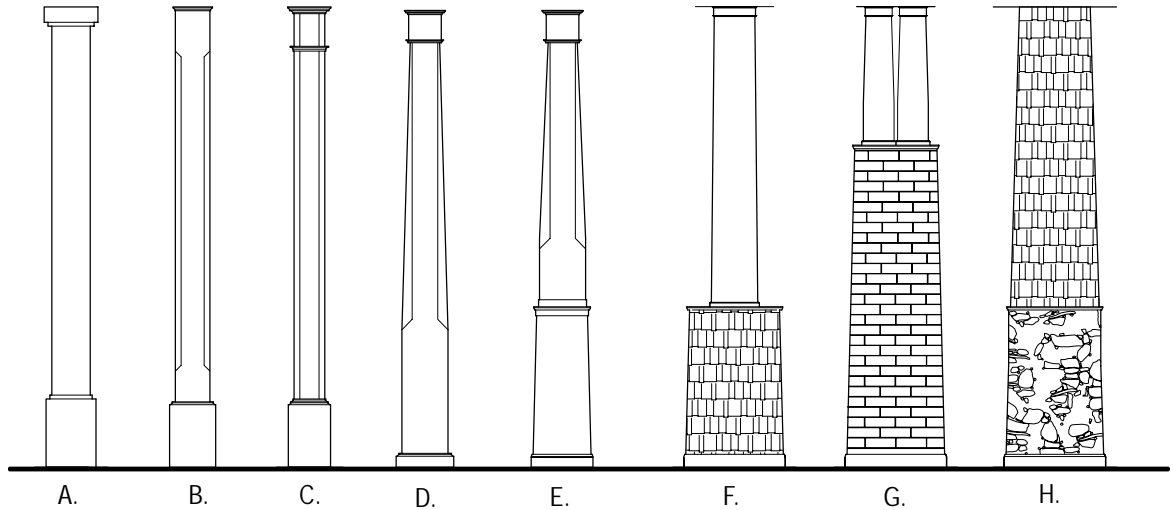

A. BOX  
 B. CHAMFERED BOX  
 C. BOX (CHAMFERED)  
 D. TAPERED BOX

E. TAPERED BOX ON PLINTH  
 F. BROAD TAPERED SQ. on PEDESTAL  
 G. DBL. BROAD TAPERED SQ. on HIGH PEDESTAL  
 H. STONE or BRICK or CEDAR SHINGLE COLUMN

1. MATERIALS: Columns
  - wood; painted.
  - pre-formed glass fibre casts will be permitted with prior approval ONLY.
2. MATERIALS: Plinths
  - wood; painted.
  - panelled exterior plywood.
  - wood shingles.
  - stucco with timber detailing.
  - brick or stone.
3. Aluminum columns or plinths are NOT encouraged.
4. Wood columns are to be 10" MIN. wide.
5. Stone/brick columns shall be 18" MIN. wide.
6. Plinths are to be 12" MIN. in depth, and square in plan.
7. Columns are to have a proportion of 1:8 (width:height).
8. All column types may be double when either freestanding or on a plinth.
9. Plinths and rail-walls (below porch balustrades) are to be of the same material as the main floor of the house, EXCEPT where the columns and/or plinths and railwalls are cedar shingle, stone, or brick.

© 1998, Jenkins & Associates Architecture and Town Planning Ltd.

Section

### III. DETAILS

Drawing Name

# COLUMNS

Drawing No.

# 1.17



February 2007

## TRADITIONAL BALUSTRADE EXAMPLES

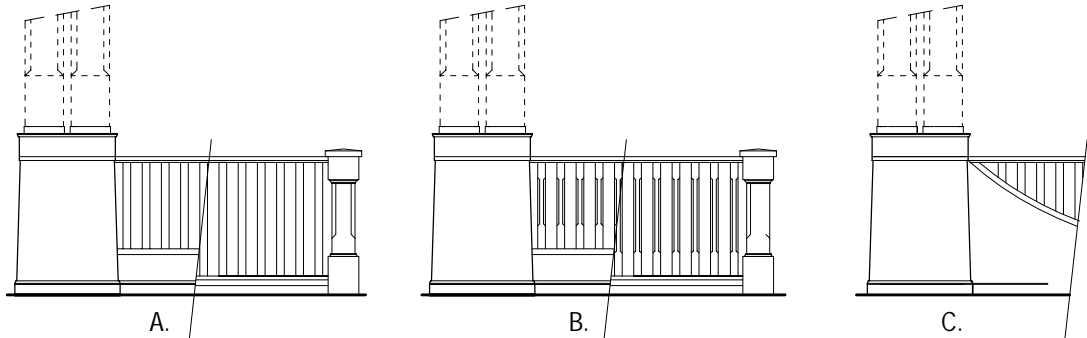

- A. 2x2 SQUARE BALUSTRADE  
 B. 2x2 CHAMFERED BALUSTRADE  
 C. CONTINUOUS PLINTH / BALUSTRADE WALL  
 D. CONTINUOUS COLUMN, PLINTH,  
 BALUSTRADE WALL.

1. MATERIALS: Wood top and bottom rails with wood balusters; ptd. or stained.
2. MATERIALS: Plinths and Balustrade Walls  
 - wood; painted.  
 - panelled exterior plywood.  
 - shingles, smooth or rough sawn.  
 - smooth stucco with timber detailing.  
 - brick, stone, masonry.
3. Plinths and rail walls are to be of the material same material.
4. Plinths and rail walls are to be of the same material as the main floor of the house, EXCEPT where the columns and/or plinths are stone/brick or cedar shingle.
5. Wood balusters shall be 2" x 2".
6. Top and bottom rails shall be 2" x 4" MIN.
7. Balustrade walls shall be 6" MIN. in depth.

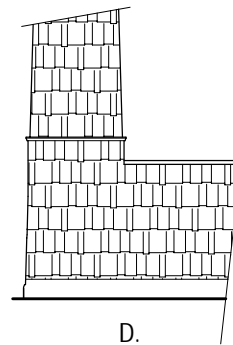
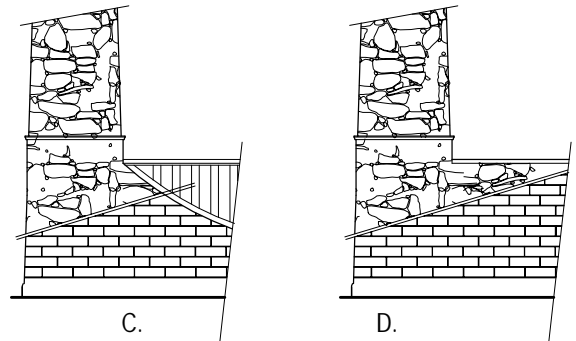

© 1998, Jenkins & Associates Architecture and Town Planning Ltd.

Section

### III. DETAILS

Drawing Name

# BALUSTRADES

Drawing No.

# 1.18

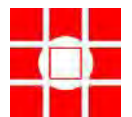

February 2007

**TRADITIONAL GABLE ENDS**

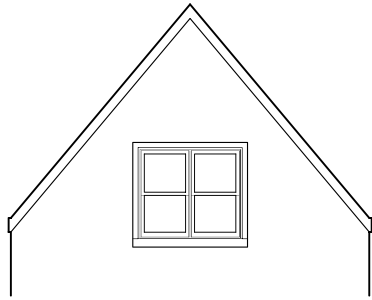

A. NO OVERHANG / PARAPETTED GABLE WALL

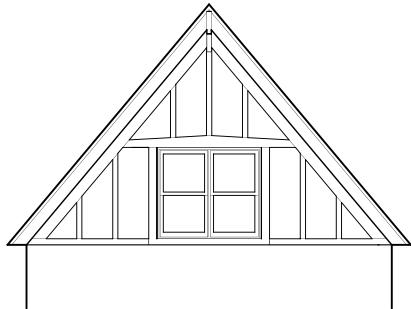

B. HALF TIMBERED - Smooth Stucco, Exterior Wood Panels between rough/smooth sawn timbers

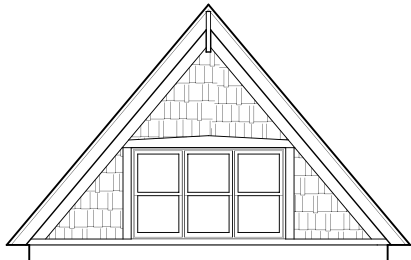

C. Rough / Smooth Sawn Wood Shingles

D. BAY TO UNDERSIDE OF EXTENDED GABLE END.

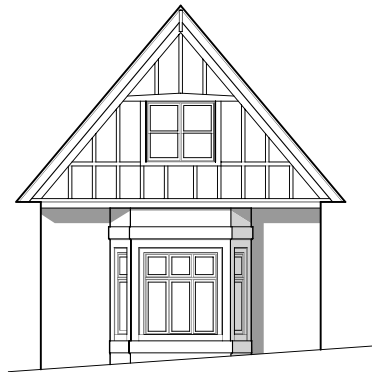

E. MAIN FLOOR BAY.

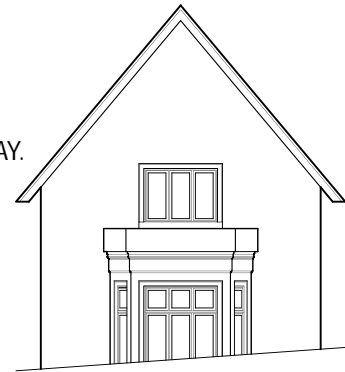

1. MATERIALS:
  - panelled exterior plywood.
  - decorative wood shingles.
  - wood shingles.
  - stucco with timber detailing.
  - stone, brick.

Roof and fascia details shall conform to  
 2. ROOFS.

Single windows are common in gable ends  
 3. above main floor bays and window gangs of 3 or more.

**Photo Credits:**  
 P.1.01 Goff, Lee, *Tudor Style: Tudor Revival Houses in America from 1890 to the Present*,  
 Universe Publishing, New York, 2002, p.64.

Section  
**III. DETAILS**  
 Drawing Name  
**GABLE ENDS**

Drawing No.  
**1.19**

February 2007

# THE DIOCESE PROPERTY

## *Tudor Style Materials & Colour Codes*

The intent of the 'Tudor Style' Materials and Colour Specifications are to assist the builders in identifying materials and colours suitable for Tudor Style buildings in the Diocese Property. The approved materials and colours are the result of research of Tudor Style buildings particular to the City of Regina. It is the combination of architectural style, and the appropriate materials and colours to the Tudor Style that results in a historically accurate representation for the neighbourhood of the Diocese Property.

Tudor Style buildings typically are smooth stucco, brick, or stone. Windows and trim are typically dark in colour. Steep gabled roofs are a strong identifying feature of Tudor Style buildings. The main gable ends are usually stucco with decorative half-timbering, although masonry is also common. When using brick, rumbled bricks with a ½" slightly tooled mortar joint are most common. Smooth stucco is the most common wall finish seen in this style.

Using the Diocese Property Codes:

- The Diocese Property Architectural Codes define approved materials for Tudor Style buildings and where the materials may be used.
- The Materials Matrix defines the type and manufacturer of approved materials for Tudor Style Houses.
- The Colour Matrix defines approved paint and stain colours for Tudor Style buildings.
- The Materials & Colours Specifications printed in colour, are intended to act as a visual guide to the matrices noted above.

It is essential to use all Code references **concurrently** to provide a comprehensive understanding of the style. This is the intent of the Diocese Property Codes.

● APPROVED ○ NOT APPROVED

**ROOFING:**

DESCRIPTION	MANUFACTURER	CODE/MATERIAL	SIZE	WARRANTY	COLOUR	COMMENTS
ASPHALT SHINGLES	BP	ECLIPSE	N/A	LIFETIME	TWILIGHT GREY	TUDOR ●
					STONEWOOD	●
					WEATHERED ROCK	●
					SHADOW BLACK	●
					AUTUMN BROWN	●
	IKO INDUSTRIES LTD.	CHATEAU	N/A	30 YEAR	HARVARD SLATE	●
					WEATHERWOOD	●
					DUAL BLACK	●
					FOREST GREEN	●
					TWILIGHT GREY	●
FIBREGLASS SHINGLES	BP	HARMONY	N/A	30 YEAR	STONEWOOD	●
					WEATHERED ROCK	●
					SHADOW BLACK	●
					AUTUMN BROWN	●
	IKO INDUSTRIES LTD.	CAMBRIDGE	N/A	25 YEAR	HARVARD SLATE ULTRA	●
					WEATHERWOOD ULTRA	●
					DUAL BLACK ULTRA	●
					FOREST GREEN ULTRA	●
	TIMBERLINE	TIMBERLINE 35	N/A	35 YEAR	CHARCOAL BLEND	●
					MISSION BROWN BLEND	●
					PEWTER GRAY BLEND	●
	ELK PREMIUM ROOFING	PRESTIQUE	N/A	30 YEAR	ANTIQUÉ SLATE	●
					WEATHERWOOD	●
					SABLEWOOD	●
					FOREST GREEN	●
CONCRETE TILE	UNICRETE PRODUCTS LTD.	3A (SLATE - STANDARD PROFILE)	N/A	N/A	NEW BARK 0342	● PERMITTED ON BUILDINGS WITH MIN. 50 FT. FRONTAGE
CONCRETE TILE	UNICRETE PRODUCTS LTD.	3A (SLATE - STANDARD PROFILE)	N/A	N/A	PARAMOUNT MOSS 0354	●
CEMBRIT SLATE	UNICRETE PRODUCTS LTD.	DIAGONAL SLATE	400 X 400mm	N/A	BLACK	●
CEMBRIT SLATE	UNICRETE PRODUCTS LTD.	DIAGONAL SLATE	600 X 600mm	N/A	BLACK	●
NATURAL SLATE	UNIVERSAL SLATE INT.	SEMI-GAUGED	30 X 15cm	N/A	SUBMIT FOR APPROVAL	●
NATURAL SLATE	UNIVERSAL SLATE INT.	SEMI-GAUGED	30 X 20cm	N/A	SUBMIT FOR APPROVAL	●
NATURAL COPPER	SUBMIT FOR APPROVAL	N/A	N/A	N/A	N/A	●
NATURAL ZINC	SUBMIT FOR APPROVAL	N/A	N/A	N/A	N/A	●
CEDAR SHINGLES	SUBMIT FOR APPROVAL	N/A	N/A	N/A	REFER TO COLOR SCHEDULE	●

**DIOCESE PROPERTY ARCHITECTURAL GUIDELINES**

**MATERIALS & COLOURS MATRIX**

**TUDOR STYLE**

**M1**

**FEBRUARY 2007**

The Owner reserves the right to adjust the guidelines as necessary. All building plans and elevations must be submitted for review and approval by the Diocese of Calgary. These guidelines are to be adhered to in addition to the requirements of the Master Site Plan. This drawing is the exclusive property of JENKINS & ASSOCIATES ARCHITECTURE AND TOWN PLANNING. Permission of the Architect in which case the reproduction must bear the name of the Architect. This drawing is not to be scaled. This drawing is to serve as a guideline ONLY.



**WALL CLADDING:**

● APPROVED ○ NOT APPROVED

DESCRIPTION	MANUFACTURER	CODE/MATERIAL	COLOUR	TUDOR	COMMENTS
WOOD FIBRE SIDING	CANEXEL	6" CEDR VUE	WHITE	○	
			ALMOND	○	
			SAND	○	
			COUNTRY RED	○	
			ACADIA	○	
			SIERRA	○	
			MIST GREY	○	
			PINE GREEN	○	
			SCOTIA BLUE	○	
	SMARTSYSTEM	SMARTLAP	REFER TO COLOUR SCHEDULE	○	
			REFINISHING THROUGH		
			UNICRETE OR BARDON INDUSTRIES		
STUCCO	IMASCO MINERALS	PREMIX 1000 - SMOOTH OR SPRAYED SANDS - SMOOTH FINISH ACRYLIC - SMOOTH FINISH	LIGHT IVORY 6-53	●	NOTE: SMOOTH OR SAND FINISH ONLY
			DARK IVORY 1-53	○	
			CANYON BRUSH 136 (1-6)	●	
			DARK HARVEST GOLD 1-46	○	
			LIGHT MOUNTAIN MIST 6-131	○	
			DARK MOUNTAIN MIST 1-131	●	
			DARK VENETIAN YELLOW 1-655	○	
			SLATE 820 (1-6)	●	
			DARK FRENCH GREY	●	
			LIGHT SUEDE 6-830	●	
			MEDIUM SUEDE 3-830	●	
			DARK SUEDE 6-830	●	
			REFER TO COLOUR SCHEDULE	●	
			REFER TO COLOUR SCHEDULE	●	
STUCCO	R/NOTEX	SMOOTH SUBSTRATE			
ACRYLIC STUCCO	ACRYLIC STUCCO	SMOOTH FINISH ACRYLIC			
HORIZ. BEVELLED WOOD SIDING	SUBMIT FOR APPROVAL	N/A	REFER TO COLOUR SCHEDULE	○	
WOOD SHINGLES	SUBMIT FOR APPROVAL	N/A	REFER TO COLOUR SCHEDULE	○	
HORIZ. BOARD & BATTEN	SUBMIT FOR APPROVAL	N/A	REFER TO COLOUR SCHEDULE	○	
HARDPLANK	JAMES HARDIE SIDING	SUBMIT FOR APPROVAL	SUBMIT FOR APPROVAL	○	

**DIOCESE  
PROPERTY  
ARCHITECTURAL  
GUIDELINES**

**MATERIALS &  
COLOURS  
MATRIX**

**TUDOR  
STYLE**

M2

**FEBRUARY 2007**

The Owner reserves the right to adjust the guidelines as necessary. All building plans and elevations must be submitted to the Site Architect for conformity to all standards, requirements of the Mayor, Site Plan, and other applicable regulations in addition to the requirements of the Mayor, Site Plan. This drawing is the exclusive property of JENKINS & ASSOCIATES ARCHITECTURE AND TOWNPLANNING LTD. and may be reproduced only with the written consent of the Architect. This drawing is not to be scaled. This drawing is to serve as a guideline ONLY.









● APPROVED ○ NOT APPROVED

**BASE MATERIAL:**

DESCRIPTION	MANUFACTURER	CODE/MATERIAL	COLOUR	TUDOR	COMMENTS
REINFORCED CEMENTITIOUS PANEL	STONETILE (CANADA)	RUSTIC TILE	ANTIQUÉ WHITE	○	
			SANDSTONE	○	
			ANTIQUÉ GREY	○	
		HERITAGE STONE	ANTIQUÉ WHITE	○	
			SANDSTONE	○	
			ANTIQUÉ GREY	○	
MANUFACTURED STONE	CULTURED STONE	RIVER ROCK	WHITEWATER	○	NOTE: CULTURED & NATURAL STONE MAY BE USED FOR BASE, FIREPLACE OR MAIN
		SPLIT FACE	GRANITE	○	GABLE FOR TUDOR
		COBBLEFIELD	OHIO	●	
		COBBLEFIELD	GRAY	●	
		COBBLEFIELD	SAN FRANCISCO	●	
		LIMESTONE	BUCKEYE	●	
		SOUTHERN LEDGESTONE	FOG	○	
		COUNTRY LEDGESTONE	CHARDONNAY	○	
		LIMESTONE	LAKE ERIE	●	
		SOUTHERN LEDGESTONE	WALNUT	○	
		SOUTHERN LEDGESTONE	CHARDONNAY	○	
		SOUTHERN LEDGESTONE	BLACK RUNDLE	○	
		SUBMIT FOR APPROVAL	SUBMIT FOR APPROVAL	●	
	SHOULDICE	SUBMIT FOR APPROVAL	SUBMIT FOR APPROVAL	●	
	CORONADO STONE	COUNTRY CASTLE	LOMPOC	●	
		COUNTRY RUBBLE	FRONTIER BLEND	●	
		COUNTRY CASTLE	GREY	●	
		COUNTRY RUBBLE	ANTIQUÉ CREAM	●	
	ELDORADO STONE	MOUNTAIN LEDGE	MESA VERDE	○	
		MOUNTAIN LEDGE	DARK RUNDLE	●	
		RUSTIC LEDGE	CASCADE	○	
		LIMESTONE	YORK	●	
		RIVER ROCK	RIO GRANDE	○	
NATURAL STONE	I-XL	RUNDLESTONE	BLACK	○	
		BLENDED	NATURAL 1" BLACK RUNDLE	○	
		SUBMIT FOR APPROVAL	W/ KOOTENAY BROWN (90/10)	○	
	SUBMIT FOR APPROVAL	SUBMIT FOR APPROVAL	SUBMIT FOR APPROVAL	●	

**DIOCESE  
PROPERTY  
ARCHITECTURAL  
GUIDELINES**

**MATERIALS &  
COLOURS  
MATRIX**

**TUDOR  
STYLE**

M5

**FEBRUARY 2007**

The Owner reserves the right to adjust the guidelines and recommendations in this matrix. All building plans and elevations must be submitted to the Site Architect for conformity to all standards. These Guidelines are to be adhered to in addition to requirements of the Master Plan.

This drawing is the exclusive property of JENKINS & ASSOCIATES ARCHITECTURE AND TOWN PLANNING LTD. and may be reproduced only with the permission of the Architect. Any other use of the reproduction must bear the name of the Architect and the date of the drawing. This drawing is to serve as a guideline ONLY.

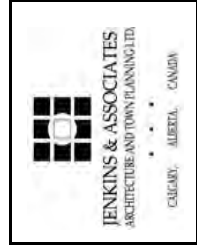

**WINDOWS AND DOORS:**

● APPROVED ○ NOT APPROVED

DESCRIPTION	MANUFACTURER	CODE / MATERIAL	SIZE	COLOUR	TUDOR	COMMENTS
METAL CLAD UNITS	SUBMIT FOR APPROVAL	N/A	REFER TO ARCH. CODES	REFER TO COLOUR SCHEDULE	●	
	ALL WEATHER WINDOWS	N/A	REFER TO ARCH. CODES	WICKER	●	
				ARCHITECTURAL BROWN	●	
				CHOCOLATE BROWN	●	
	CWD	N/A		SANDLEWOOD	●	
				BRONZE METALLIC	●	
PVC UNITS	SUBMIT FOR APPROVAL	N/A	REFER TO ARCH. CODES	REFER TO COLOUR SCHEDULE	●	
	ALL WEATHER WINDOWS			WICKER	●	
	CWD			SANDLEWOOD	●	
WOOD UNITS	SUBMIT FOR APPROVAL	N/A	REFER TO ARCH. CODES	REFER TO COLOUR SCHEDULE	●	

**EXTERIOR DETAILING:**

● APPROVED ○ NOT APPROVED

DESCRIPTION	MANUFACTURER	CODE / MATERIAL	SIZE	COLOUR	TUDOR	COMMENTS
SHUTTERS	SUBMIT FOR APPROVAL	N/A	REFER TO ARCH. CODES	REFER TO COLOUR SCHEDULE	○	
TRIM	N/A	ROUGH OR SMOOTH SAWN WOOD*	REFER TO ARCH. CODES	REFER TO COLOUR SCHEDULE	●	
TRIM	SMARTSYSTEM / JAMES HARDIE	SMART TRIM / HARDIE TRIM	REFER TO ARCH. CODES	REFER TO COLOUR SCHEDULE	●	
CORNICE, FRIEZE DETAILS, SILL, HEADER	SUBMIT FOR APPROVAL	WOOD, MOLDED POLY	REFER TO ARCH. CODE	REFER TO COLOUR SCHEDULE	●	
CORNICE, FRIEZE DETAILS, SILL, HEADER	STONETILE (CANADA) LTD.	REINFORCED CAST CONC. MOULDING	REFER TO ARCH. CODE	SUBMIT FOR APPROVAL	●	OR APPROVED EQUAL
FASCIA	SUBMIT FOR APPROVAL	WOOD, ALUMINUM ONLY	REFER TO ARCH. CODE	REFER TO COLOUR SCHEDULE	●	
SOFFITS	SUBMIT FOR APPROVAL	WOOD, ALUMINUM, OR VINYL	N/A	REFER TO COLOUR SCHEDULE	●	
FASCIA / SOFFITS	GENTEK	ALUMINUM		NUTMEG	●	
				SLATE	●	
				SABLE	●	
				BLACK	●	
				ROYAL LINEN #924	○	
	MONARCH SIDING CENTRE	ALUMINUM		ROYAL CLAY #913	○	
				ROYAL BEIGE #902	○	
	CAN-ALUM BUILDING PRODUCTS	ALUMINUM		REYNOLDS ROYAL LINEN #924	○	
				REYNOLDS ROYAL CLAY #913	○	
				REYNOLDS IVORY #902	○	
CORNER BOARDS	N/A	WOOD, APPROVED VINYL	REFER TO ARCH. CODE	REFER TO COLOUR SCHEDULE	●	
EAVESTROUGHS AND DOWNSPOUTS	N/A	ALUMINUM	STANDARD RESIDENTIAL	MATCH TO TRIM COLOURS	●	
FENCING	SUBMIT FOR APPROVAL	WROUGHT IRON	REFER TO ARCH. CODES	BLACK ONLY	●	SUBMIT SHOP DRAWING
FENCING	SUBMIT FOR APPROVAL	WOOD	REFER TO ARCH. CODES	WHITE ONLY	●	

\*UNLESS OTHERWISE SPECIFIED

**DIOCESE  
PROPERTY  
ARCHITECTURAL  
GUIDELINES**

**MATERIALS &  
COLOURS  
MATRIX**

**TUDOR  
STYLE**

M6

**FEBRUARY 2007**

The Owner reserves the right to adjust the guidelines as necessary. All building plans and elevations must be prepared in accordance with the guidelines. These Guidelines are to be adhered to in addition to regulations of the Master Site Plan.  
This drawing is the exclusive property of JENKINS ARCHITECTURE AND TOWN PLANNING LTD. and may be reproduced only with the permission of the Architect in which case the reproduction must bear the name of the Architect. It is not to be scaled. This drawing is to serve as a guideline ONLY.



**JENKINS & ASSOCIATES  
ARCHITECTURE AND TOWN PLANNING LTD.**  
CALGARY ALBERTA CANADA

**COLOUR SCHEDULE:**

MANUFACTURER	COLOUR (OLD #)	TUDOR								COMMENTS			
		MAIN BODY OF HOUSE	TRIM	DOORS	WINDOWS	DOOR & WINDOW SURROUNDS	SHUTTERS	COLUMNS & BALUSTRADES	CORNICE & FRIEZE DETAILING		GABLE ENDS	SOFFITS AND FASCIA	
BENJAMIN MOORE	HC-26	<input type="checkbox"/>	<input type="checkbox"/>	<input type="checkbox"/>	<input type="checkbox"/>	<input type="checkbox"/>	<input type="checkbox"/>	<input type="checkbox"/>	<input type="checkbox"/>	<input type="checkbox"/>	<input type="checkbox"/>	<input type="checkbox"/>	
	HC-76	<input type="checkbox"/>	<input type="checkbox"/>	<input type="checkbox"/>	<input type="checkbox"/>	<input type="checkbox"/>	<input type="checkbox"/>	<input type="checkbox"/>	<input type="checkbox"/>	<input type="checkbox"/>	<input type="checkbox"/>	<input type="checkbox"/>	
	HC-79	<input type="checkbox"/>	<input type="checkbox"/>	<input type="checkbox"/>	<input type="checkbox"/>	<input type="checkbox"/>	<input type="checkbox"/>	<input type="checkbox"/>	<input type="checkbox"/>	<input type="checkbox"/>	<input type="checkbox"/>	<input type="checkbox"/>	
	HC-82	<input type="checkbox"/>	<input type="checkbox"/>	<input type="checkbox"/>	<input type="checkbox"/>	<input type="checkbox"/>	<input type="checkbox"/>	<input type="checkbox"/>	<input type="checkbox"/>	<input type="checkbox"/>	<input type="checkbox"/>	<input type="checkbox"/>	
	HC-85	<input type="checkbox"/>	<input type="checkbox"/>	<input type="checkbox"/>	<input type="checkbox"/>	<input type="checkbox"/>	<input type="checkbox"/>	<input type="checkbox"/>	<input type="checkbox"/>	<input type="checkbox"/>	<input type="checkbox"/>	<input type="checkbox"/>	
	HC-86	<input type="checkbox"/>	<input type="checkbox"/>	<input type="checkbox"/>	<input type="checkbox"/>	<input type="checkbox"/>	<input type="checkbox"/>	<input type="checkbox"/>	<input type="checkbox"/>	<input type="checkbox"/>	<input type="checkbox"/>	<input type="checkbox"/>	
	HC-88	<input type="checkbox"/>	<input type="checkbox"/>	<input type="checkbox"/>	<input type="checkbox"/>	<input type="checkbox"/>	<input type="checkbox"/>	<input type="checkbox"/>	<input type="checkbox"/>	<input type="checkbox"/>	<input type="checkbox"/>	<input type="checkbox"/>	
	HC-89	<input type="checkbox"/>	<input type="checkbox"/>	<input type="checkbox"/>	<input type="checkbox"/>	<input type="checkbox"/>	<input type="checkbox"/>	<input type="checkbox"/>	<input type="checkbox"/>	<input type="checkbox"/>	<input type="checkbox"/>	<input type="checkbox"/>	
	HC-95	<input type="checkbox"/>	<input type="checkbox"/>	<input type="checkbox"/>	<input type="checkbox"/>	<input type="checkbox"/>	<input type="checkbox"/>	<input type="checkbox"/>	<input type="checkbox"/>	<input type="checkbox"/>	<input type="checkbox"/>	<input type="checkbox"/>	
	HC-100	<input type="checkbox"/>	<input type="checkbox"/>	<input type="checkbox"/>	<input type="checkbox"/>	<input type="checkbox"/>	<input type="checkbox"/>	<input type="checkbox"/>	<input type="checkbox"/>	<input type="checkbox"/>	<input type="checkbox"/>	<input type="checkbox"/>	
	HC-101	<input type="checkbox"/>	<input type="checkbox"/>	<input type="checkbox"/>	<input type="checkbox"/>	<input type="checkbox"/>	<input type="checkbox"/>	<input type="checkbox"/>	<input type="checkbox"/>	<input type="checkbox"/>	<input type="checkbox"/>	<input type="checkbox"/>	
	HC-102	<input type="checkbox"/>	<input type="checkbox"/>	<input type="checkbox"/>	<input type="checkbox"/>	<input type="checkbox"/>	<input type="checkbox"/>	<input type="checkbox"/>	<input type="checkbox"/>	<input type="checkbox"/>	<input type="checkbox"/>	<input type="checkbox"/>	
	HC-103	<input type="checkbox"/>	<input type="checkbox"/>	<input type="checkbox"/>	<input type="checkbox"/>	<input type="checkbox"/>	<input type="checkbox"/>	<input type="checkbox"/>	<input type="checkbox"/>	<input type="checkbox"/>	<input type="checkbox"/>	<input type="checkbox"/>	
	HC-106	<input type="checkbox"/>	<input type="checkbox"/>	<input type="checkbox"/>	<input type="checkbox"/>	<input type="checkbox"/>	<input type="checkbox"/>	<input type="checkbox"/>	<input type="checkbox"/>	<input type="checkbox"/>	<input type="checkbox"/>	<input type="checkbox"/>	
	CC-480	<input type="checkbox"/>	<input checked="" type="checkbox"/>	<input type="checkbox"/>	<input checked="" type="checkbox"/>	<input type="checkbox"/>	<input checked="" type="checkbox"/>	<input type="checkbox"/>	<input type="checkbox"/>	<input type="checkbox"/>	<input type="checkbox"/>	<input type="checkbox"/>	To match CWD's Sandilewood windows
	2109-10	<input type="checkbox"/>	<input type="checkbox"/>	<input type="checkbox"/>	<input type="checkbox"/>	<input type="checkbox"/>	<input type="checkbox"/>	<input type="checkbox"/>	<input type="checkbox"/>	<input type="checkbox"/>	<input type="checkbox"/>	<input type="checkbox"/>	
	2114-10	<input type="checkbox"/>	<input type="checkbox"/>	<input type="checkbox"/>	<input type="checkbox"/>	<input type="checkbox"/>	<input type="checkbox"/>	<input type="checkbox"/>	<input type="checkbox"/>	<input type="checkbox"/>	<input type="checkbox"/>	<input type="checkbox"/>	
	2115-10	<input type="checkbox"/>	<input type="checkbox"/>	<input type="checkbox"/>	<input type="checkbox"/>	<input type="checkbox"/>	<input type="checkbox"/>	<input type="checkbox"/>	<input type="checkbox"/>	<input type="checkbox"/>	<input type="checkbox"/>	<input type="checkbox"/>	
	2128-10	<input type="checkbox"/>	<input type="checkbox"/>	<input type="checkbox"/>	<input type="checkbox"/>	<input type="checkbox"/>	<input type="checkbox"/>	<input type="checkbox"/>	<input type="checkbox"/>	<input type="checkbox"/>	<input type="checkbox"/>	<input type="checkbox"/>	
	2134-10	<input type="checkbox"/>	<input type="checkbox"/>	<input type="checkbox"/>	<input type="checkbox"/>	<input type="checkbox"/>	<input type="checkbox"/>	<input type="checkbox"/>	<input type="checkbox"/>	<input type="checkbox"/>	<input type="checkbox"/>	<input type="checkbox"/>	
	2134-20	<input type="checkbox"/>	<input type="checkbox"/>	<input type="checkbox"/>	<input type="checkbox"/>	<input type="checkbox"/>	<input type="checkbox"/>	<input type="checkbox"/>	<input type="checkbox"/>	<input type="checkbox"/>	<input type="checkbox"/>	<input type="checkbox"/>	
	2139-20	<input type="checkbox"/>	<input type="checkbox"/>	<input type="checkbox"/>	<input type="checkbox"/>	<input type="checkbox"/>	<input type="checkbox"/>	<input type="checkbox"/>	<input type="checkbox"/>	<input type="checkbox"/>	<input type="checkbox"/>	<input type="checkbox"/>	
	2089-20 (034)	<input type="checkbox"/>	<input type="checkbox"/>	<input type="checkbox"/>	<input type="checkbox"/>	<input type="checkbox"/>	<input type="checkbox"/>	<input type="checkbox"/>	<input type="checkbox"/>	<input type="checkbox"/>	<input type="checkbox"/>	<input type="checkbox"/>	
	2089-10 (035)	<input type="checkbox"/>	<input type="checkbox"/>	<input type="checkbox"/>	<input type="checkbox"/>	<input type="checkbox"/>	<input type="checkbox"/>	<input type="checkbox"/>	<input type="checkbox"/>	<input type="checkbox"/>	<input type="checkbox"/>	<input type="checkbox"/>	
	2085-10 (042)	<input type="checkbox"/>	<input type="checkbox"/>	<input type="checkbox"/>	<input type="checkbox"/>	<input type="checkbox"/>	<input type="checkbox"/>	<input type="checkbox"/>	<input type="checkbox"/>	<input type="checkbox"/>	<input type="checkbox"/>	<input type="checkbox"/>	
	R-9929 (063)	<input type="checkbox"/>	<input type="checkbox"/>	<input type="checkbox"/>	<input type="checkbox"/>	<input type="checkbox"/>	<input type="checkbox"/>	<input type="checkbox"/>	<input type="checkbox"/>	<input type="checkbox"/>	<input type="checkbox"/>	<input type="checkbox"/>	
	CC-180 (170)	<input type="checkbox"/>	<input type="checkbox"/>	<input type="checkbox"/>	<input type="checkbox"/>	<input type="checkbox"/>	<input type="checkbox"/>	<input type="checkbox"/>	<input type="checkbox"/>	<input type="checkbox"/>	<input type="checkbox"/>	<input type="checkbox"/>	
	HC-12 (171)	<input type="checkbox"/>	<input type="checkbox"/>	<input type="checkbox"/>	<input type="checkbox"/>	<input type="checkbox"/>	<input type="checkbox"/>	<input type="checkbox"/>	<input type="checkbox"/>	<input type="checkbox"/>	<input type="checkbox"/>	<input type="checkbox"/>	
	2154-40 (194)	<input type="checkbox"/>	<input type="checkbox"/>	<input type="checkbox"/>	<input type="checkbox"/>	<input type="checkbox"/>	<input type="checkbox"/>	<input type="checkbox"/>	<input type="checkbox"/>	<input type="checkbox"/>	<input type="checkbox"/>	<input type="checkbox"/>	
	R-9936 (195)	<input type="checkbox"/>	<input type="checkbox"/>	<input type="checkbox"/>	<input type="checkbox"/>	<input type="checkbox"/>	<input type="checkbox"/>	<input type="checkbox"/>	<input type="checkbox"/>	<input type="checkbox"/>	<input type="checkbox"/>	<input type="checkbox"/>	
	2148-10 (231)	<input type="checkbox"/>	<input type="checkbox"/>	<input type="checkbox"/>	<input type="checkbox"/>	<input type="checkbox"/>	<input type="checkbox"/>	<input type="checkbox"/>	<input type="checkbox"/>	<input type="checkbox"/>	<input type="checkbox"/>	<input type="checkbox"/>	
	2148-20 (251)	<input type="checkbox"/>	<input type="checkbox"/>	<input type="checkbox"/>	<input type="checkbox"/>	<input type="checkbox"/>	<input type="checkbox"/>	<input type="checkbox"/>	<input type="checkbox"/>	<input type="checkbox"/>	<input type="checkbox"/>	<input type="checkbox"/>	
	HC-22 (273)	<input type="checkbox"/>	<input type="checkbox"/>	<input type="checkbox"/>	<input type="checkbox"/>	<input type="checkbox"/>	<input type="checkbox"/>	<input type="checkbox"/>	<input type="checkbox"/>	<input type="checkbox"/>	<input type="checkbox"/>	<input type="checkbox"/>	
	HC-122 (441)	<input type="checkbox"/>	<input type="checkbox"/>	<input type="checkbox"/>	<input type="checkbox"/>	<input type="checkbox"/>	<input type="checkbox"/>	<input type="checkbox"/>	<input type="checkbox"/>	<input type="checkbox"/>	<input type="checkbox"/>	<input type="checkbox"/>	
	CC-630 (469)	<input type="checkbox"/>	<input type="checkbox"/>	<input type="checkbox"/>	<input type="checkbox"/>	<input type="checkbox"/>	<input type="checkbox"/>	<input type="checkbox"/>	<input type="checkbox"/>	<input type="checkbox"/>	<input type="checkbox"/>	<input type="checkbox"/>	
	R-9993	<input type="checkbox"/>	<input checked="" type="checkbox"/>	<input type="checkbox"/>	<input checked="" type="checkbox"/>	<input type="checkbox"/>	<input checked="" type="checkbox"/>	<input type="checkbox"/>	<input type="checkbox"/>	<input type="checkbox"/>	<input type="checkbox"/>	<input type="checkbox"/>	To match All Weather Windows Wicker windows

● APPROVED ○ NOT APPROVED

**DIOCESE PROPERTY ARCHITECTURAL GUIDELINES**

**COLOURS MATRIX**

**TUDOR STYLE**

M7

**FEBRUARY 2007**

The owner reserves the right to adjust the guidelines as required. All building plans and variations must be submitted to the Site Architect for conformity to all standards. These Guidelines are to be addressed to in addition to the following: This drawing is the exclusive property of JENKINS & ASSOCIATES ARCHITECTURE AND TOWN PLANNING LTD. and may be reproduced only with the permission of the Architect. The reproduction must bear the name of the Architect. This drawing is to be used as a guideline ONLY.



COLOUR SCHEDULE:  APPROVED  NOT APPROVED

MANUFACTURER	COLOUR (OLD #)	TUDOR								COMMENTS			
		MAIN BODY OF HOUSE	TRIM	DOORS	WINDOWS	DOOR & WINDOW SURROUNDS	SHUTTERS	COLUMNS & BALUSTRADES	CORNICE & FRIEZE DETAILING		GABLE ENDS	SOFFITS AND FASCIA	
BENJAMIN MOORE	2142-30 (511)	<input checked="" type="radio"/>	<input type="radio"/>	<input type="radio"/>	<input type="radio"/>	<input type="radio"/>	<input type="radio"/>	<input type="radio"/>	<input type="radio"/>	<input type="radio"/>	<input type="radio"/>	<input type="radio"/>	
	2143-10 (517)	<input type="radio"/>	<input type="radio"/>	<input type="radio"/>	<input type="radio"/>	<input type="radio"/>	<input type="radio"/>	<input type="radio"/>	<input type="radio"/>	<input type="radio"/>	<input type="radio"/>	<input type="radio"/>	
	2143-20 (525)	<input type="radio"/>	<input type="radio"/>	<input type="radio"/>	<input type="radio"/>	<input type="radio"/>	<input type="radio"/>	<input type="radio"/>	<input type="radio"/>	<input type="radio"/>	<input type="radio"/>	<input type="radio"/>	
	HC-135 (644)	<input type="radio"/>	<input type="radio"/>	<input type="radio"/>	<input type="radio"/>	<input type="radio"/>	<input type="radio"/>	<input type="radio"/>	<input type="radio"/>	<input type="radio"/>	<input type="radio"/>	<input type="radio"/>	
	OC-120 (926)	<input checked="" type="radio"/>	<input type="radio"/>	<input type="radio"/>	<input type="radio"/>	<input type="radio"/>	<input type="radio"/>	<input type="radio"/>	<input type="radio"/>	<input type="radio"/>	<input type="radio"/>	<input type="radio"/>	
	OC-132 (927)	<input checked="" type="radio"/>	<input type="radio"/>	<input type="radio"/>	<input type="radio"/>	<input type="radio"/>	<input type="radio"/>	<input type="radio"/>	<input type="radio"/>	<input type="radio"/>	<input type="radio"/>	<input type="radio"/>	
	OC-108 (931)	<input checked="" type="radio"/>	<input type="radio"/>	<input type="radio"/>	<input type="radio"/>	<input type="radio"/>	<input type="radio"/>	<input type="radio"/>	<input type="radio"/>	<input type="radio"/>	<input type="radio"/>	<input type="radio"/>	
	OC-109 (932)	<input checked="" type="radio"/>	<input type="radio"/>	<input type="radio"/>	<input type="radio"/>	<input type="radio"/>	<input type="radio"/>	<input type="radio"/>	<input type="radio"/>	<input type="radio"/>	<input type="radio"/>	<input type="radio"/>	
	OC-130 (967)	<input checked="" type="radio"/>	<input type="radio"/>	<input type="radio"/>	<input type="radio"/>	<input type="radio"/>	<input type="radio"/>	<input type="radio"/>	<input type="radio"/>	<input type="radio"/>	<input type="radio"/>	<input type="radio"/>	
	HC-41 (1099)	<input type="radio"/>	<input type="radio"/>	<input type="radio"/>	<input type="radio"/>	<input type="radio"/>	<input type="radio"/>	<input type="radio"/>	<input type="radio"/>	<input type="radio"/>	<input type="radio"/>	<input type="radio"/>	
	CC-420 (1104)	<input type="radio"/>	<input type="radio"/>	<input type="radio"/>	<input type="radio"/>	<input type="radio"/>	<input type="radio"/>	<input type="radio"/>	<input type="radio"/>	<input type="radio"/>	<input type="radio"/>	<input type="radio"/>	
	2161-30 (1113)	<input type="radio"/>	<input type="radio"/>	<input type="radio"/>	<input type="radio"/>	<input type="radio"/>	<input type="radio"/>	<input type="radio"/>	<input type="radio"/>	<input type="radio"/>	<input type="radio"/>	<input type="radio"/>	
	2163-10 (1134)	<input type="radio"/>	<input type="radio"/>	<input type="radio"/>	<input type="radio"/>	<input type="radio"/>	<input type="radio"/>	<input type="radio"/>	<input type="radio"/>	<input type="radio"/>	<input type="radio"/>	<input type="radio"/>	
	HC-68 (1238)	<input type="radio"/>	<input checked="" type="radio"/>	<input type="radio"/>	<input type="radio"/>	<input type="radio"/>	<input type="radio"/>	<input type="radio"/>	<input type="radio"/>	<input type="radio"/>	<input type="radio"/>	<input type="radio"/>	
	2172-30 (1301)	<input type="radio"/>	<input type="radio"/>	<input type="radio"/>	<input type="radio"/>	<input type="radio"/>	<input type="radio"/>	<input type="radio"/>	<input type="radio"/>	<input type="radio"/>	<input type="radio"/>	<input type="radio"/>	
	HC-108 (1487)	<input checked="" type="radio"/>	<input type="radio"/>	<input type="radio"/>	<input type="radio"/>	<input type="radio"/>	<input type="radio"/>	<input type="radio"/>	<input type="radio"/>	<input type="radio"/>	<input type="radio"/>	<input type="radio"/>	
	HC-107 (1488)	<input checked="" type="radio"/>	<input type="radio"/>	<input type="radio"/>	<input type="radio"/>	<input type="radio"/>	<input type="radio"/>	<input type="radio"/>	<input type="radio"/>	<input type="radio"/>	<input type="radio"/>	<input type="radio"/>	
	HC-100 (1489)	<input checked="" type="radio"/>	<input type="radio"/>	<input type="radio"/>	<input type="radio"/>	<input type="radio"/>	<input type="radio"/>	<input type="radio"/>	<input type="radio"/>	<input type="radio"/>	<input type="radio"/>	<input type="radio"/>	
	2142-30 (1526)	<input checked="" type="radio"/>	<input type="radio"/>	<input type="radio"/>	<input type="radio"/>	<input type="radio"/>	<input type="radio"/>	<input type="radio"/>	<input type="radio"/>	<input type="radio"/>	<input type="radio"/>	<input type="radio"/>	
	2137-30 (1540)	<input checked="" type="radio"/>	<input type="radio"/>	<input type="radio"/>	<input type="radio"/>	<input type="radio"/>	<input type="radio"/>	<input type="radio"/>	<input type="radio"/>	<input type="radio"/>	<input type="radio"/>	<input type="radio"/>	
R-9984 (1582)	<input checked="" type="radio"/>	<input type="radio"/>	<input type="radio"/>	<input type="radio"/>	<input type="radio"/>	<input type="radio"/>	<input type="radio"/>	<input type="radio"/>	<input type="radio"/>	<input type="radio"/>	<input type="radio"/>		
WHITE	<input type="radio"/>	<input type="radio"/>	<input type="radio"/>	<input type="radio"/>	<input type="radio"/>	<input type="radio"/>	<input type="radio"/>	<input type="radio"/>	<input type="radio"/>	<input type="radio"/>	<input type="radio"/>		
BLACK	<input type="radio"/>	<input checked="" type="radio"/>	<input type="radio"/>	<input type="radio"/>	<input type="radio"/>	<input type="radio"/>	<input type="radio"/>	<input type="radio"/>	<input type="radio"/>	<input type="radio"/>	<input type="radio"/>		
BEHR STAINS	704	<input type="radio"/>	<input type="radio"/>	<input type="radio"/>	<input type="radio"/>	<input type="radio"/>	<input type="radio"/>	<input type="radio"/>	<input type="radio"/>	<input type="radio"/>	<input type="radio"/>		
	708	<input type="radio"/>	<input checked="" type="radio"/>	<input type="radio"/>	<input type="radio"/>	<input type="radio"/>	<input type="radio"/>	<input type="radio"/>	<input type="radio"/>	<input type="radio"/>	<input type="radio"/>		
	710	<input type="radio"/>	<input checked="" type="radio"/>	<input type="radio"/>	<input type="radio"/>	<input type="radio"/>	<input type="radio"/>	<input type="radio"/>	<input type="radio"/>	<input type="radio"/>	<input type="radio"/>		
	712	<input type="radio"/>	<input checked="" type="radio"/>	<input type="radio"/>	<input type="radio"/>	<input type="radio"/>	<input type="radio"/>	<input type="radio"/>	<input type="radio"/>	<input type="radio"/>	<input type="radio"/>		
	720	<input type="radio"/>	<input type="radio"/>	<input type="radio"/>	<input type="radio"/>	<input type="radio"/>	<input type="radio"/>	<input type="radio"/>	<input type="radio"/>	<input type="radio"/>	<input type="radio"/>		
	723	<input type="radio"/>	<input type="radio"/>	<input type="radio"/>	<input type="radio"/>	<input type="radio"/>	<input type="radio"/>	<input type="radio"/>	<input type="radio"/>	<input type="radio"/>	<input type="radio"/>		
	724	<input type="radio"/>	<input type="radio"/>	<input type="radio"/>	<input type="radio"/>	<input type="radio"/>	<input type="radio"/>	<input type="radio"/>	<input type="radio"/>	<input type="radio"/>	<input type="radio"/>		
	725	<input type="radio"/>	<input checked="" type="radio"/>	<input type="radio"/>	<input type="radio"/>	<input type="radio"/>	<input type="radio"/>	<input type="radio"/>	<input type="radio"/>	<input type="radio"/>	<input type="radio"/>		
	728	<input type="radio"/>	<input type="radio"/>	<input type="radio"/>	<input type="radio"/>	<input type="radio"/>	<input type="radio"/>	<input type="radio"/>	<input type="radio"/>	<input type="radio"/>	<input type="radio"/>		
BEHR HI-GLOSS ENAMEL	CANDY APPLE	<input type="radio"/>	<input type="radio"/>	<input type="radio"/>	<input type="radio"/>	<input type="radio"/>	<input type="radio"/>	<input type="radio"/>	<input type="radio"/>	<input type="radio"/>	<input type="radio"/>		
	TEAL	<input type="radio"/>	<input type="radio"/>	<input type="radio"/>	<input type="radio"/>	<input type="radio"/>	<input type="radio"/>	<input type="radio"/>	<input type="radio"/>	<input type="radio"/>	<input type="radio"/>		
	BLACK BLACK	<input type="radio"/>	<input type="radio"/>	<input type="radio"/>	<input type="radio"/>	<input type="radio"/>	<input type="radio"/>	<input type="radio"/>	<input type="radio"/>	<input type="radio"/>	<input type="radio"/>		
COLOR YOUR WORLD	5519	<input type="radio"/>	<input type="radio"/>	<input type="radio"/>	<input type="radio"/>	<input type="radio"/>	<input type="radio"/>	<input type="radio"/>	<input type="radio"/>	<input type="radio"/>	<input type="radio"/>		
	5719	<input type="radio"/>	<input type="radio"/>	<input type="radio"/>	<input type="radio"/>	<input type="radio"/>	<input type="radio"/>	<input type="radio"/>	<input type="radio"/>	<input type="radio"/>	<input type="radio"/>		
	6519	<input type="radio"/>	<input type="radio"/>	<input type="radio"/>	<input type="radio"/>	<input type="radio"/>	<input type="radio"/>	<input type="radio"/>	<input type="radio"/>	<input type="radio"/>	<input type="radio"/>		

**DIOCESE PROPERTY ARCHITECTURAL GUIDELINES**

**TUDOR MATRIX**

**TUDOR STYLE**

M8

**FEBRUARY 2007**

The Owner reserves the right to adjust the guidelines. All building plans and elevations must be submitted to the Site Architect for conformity to all standards. These guidelines are to be used in addition to the standards of the City of Calgary. This drawing is the exclusive property of JENKINS & ASSOCIATES ARCHITECTURE AND TOWN PLANNING. It is not to be reproduced or used in any form without the name of the Architect. This drawing is not to be scaled. This drawing is to serve as a guideline ONLY.



**JENKINS & ASSOCIATES**  
ARCHITECTURE AND TOWN PLANNING LTD.  
CALGARY ALBERTA CANADA

DIOCESE  
PROPERTY



ARCHITECTURAL  
CODES

2

COLONIAL STYLE



## *Colonial Style Precedents*

Provided is a selection of photographic examples of buildings in the Colonial style. These represent good examples of the Colonial style for the Diocese Property.

Colonial style buildings are typically symmetrical in elevation with the central focus being the front door. The most common type of Colonial house is a two-storey dwelling with a simple rectangular footprint; bungalows are rarely seen in the Colonial style. The same symmetrical configuration is prevalent on larger apartment buildings. Asymmetrical facades with an off-center door are also seen in the style on narrow lot houses or townhouses, however, they are not as common as symmetrical facades.

A decorative crown pediment supported by pilasters or a gabled entry porch typically accentuates the front door of Colonial style buildings. The gabled entry is usually centered on the front door and supported by columns. Windows and window bays (on the main floor only) are symmetrically balanced around the central front entry.

The windows are typically double hung sashes, with multi-pane glazing in one or both sashes. Windows are not doubled in pairs, although 3-ganged windows are commonly found on the main floor. The roof overhang is minimal, usually a maximum of 12". A decorative cornice is usually located where the wall meets the eave.

Roof forms are typically a simple gable or hipped roof, often with symmetrically organized dormers.

The main body of a Colonial style building is commonly clad in brick (with cream coloured grout with struck joints), or with cream or white siding with dark green or black shutters and door. Trim colours and window frame colours are always white on Colonial style buildings.





**Entry porches identify individual units in townhouse developments.**



**The roof overhang is minimal, usually a maximum of 12”.**

**A decorative cornice is usually located where the wall meets the eave.**

**Roofs are typically gabled or hipped, often with symmetrically organized dormers.**

© 1998, Jenkins & Associates Architecture and Town Planning Ltd.

Section

I. Building Form

Drawing Name

**HOUSE PRECEDENTS**

Drawing No.

**2.01**

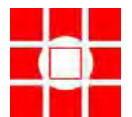

February 2007



**Bays may be used in place of ganged windows on main floor.**

**Cornice is emphasized with tooth-like dentils or other decorative moldings.**



**Flush entries with stoops are common: paneled door, with decorative crown, supported by decorative pilasters.**

**Trim colours and window frames are always white or off-white on Colonial style buildings.**

© 1998, Jenkins & Associates Architecture and Town Planning Ltd.

Section

I. Building Form

Drawing Name

**HOUSE PRECEDENTS**

Drawing No.

**2.02**



February 2007



**Colonial style townhouses.**



**Symmetrical facades are typical in the Colonial style.**

© 1998, Jenkins & Associates Architecture and Town Planning Ltd.

Section

**I. Building Form**

Drawing Name

**HOUSE PRECEDENTS**

Drawing No.

**2.03**



February 2007

### 3-BAY

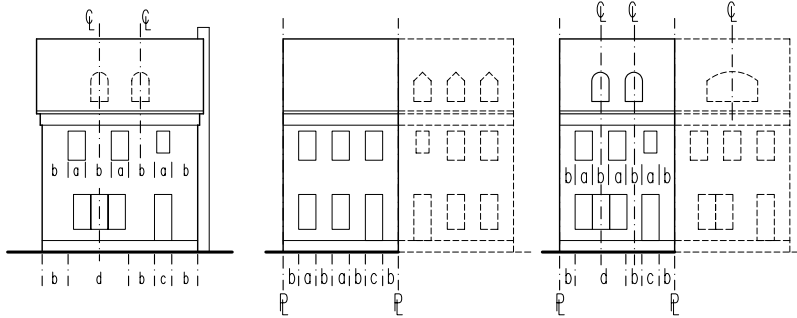

### 5-BAY

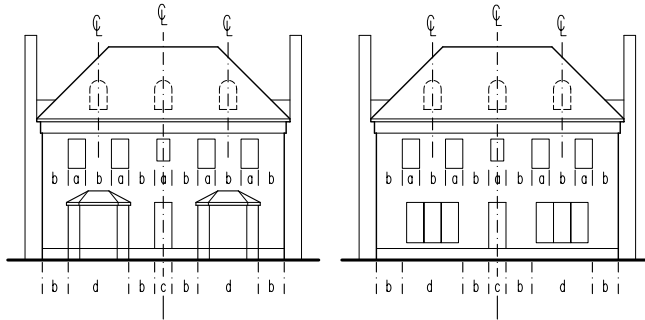

### 7-BAY APARTMENT

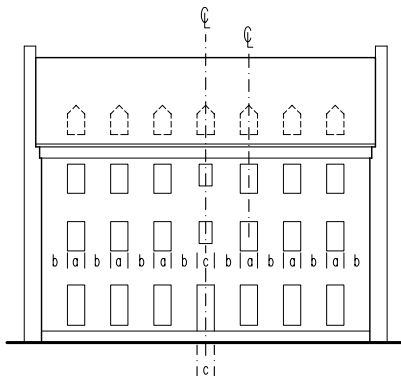

1. **MATERIALS: Main House**  
 - brick, stone, horizontal wood siding, wood fibre siding, fibre cement siding.  
 - materials shall be the same over all elevations of the main body of the house.
2. **MATERIALS: Side Wings**  
 - to be panelled wood and detailed as a "porch" with infill panels.
3. **MATERIALS: Rear Wings**  
 - may be wood siding (real or pre-formed panels) if the main body of the house is in brick or stone. Vinyl siding will NOT be permitted in this application.
4. **MATERIALS: Building Base**  
 - to be brick, stone, or simulated stone.  
 - typically the base is the height of the foundation.
5. Additions to the basic building are to be in the form of side or rear wings. These additions are to be less than the main body of the house in both width and height.
6. Side wings may be flat-roofed (with parapet or balustrade), side gabled, or hipped.
7. Bays may be used in place of ganged windows on the main floor.
8. Apartments are to be three storeys to the eave.
9. Porches and Bays are not permitted on apartment buildings.
10. Chimneys shall appear on side elevations only. Chimneys shall never appear on front elevations.

© 1998, Jenkins & Associates Architecture and Town Planning Ltd.

Section

## I. Building Form

Drawing Name

# STREET ELEVATION

Drawing No.

# 2.04



February 2007

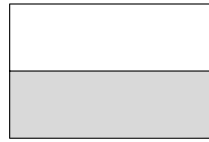

A. SIDE GABLE

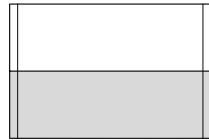

B. SIDE GABLE w/ END PARAPET WALL

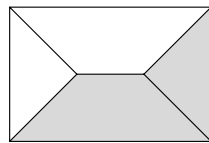

C. HIPPED

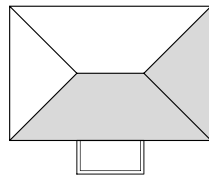

D. FRONT ENTRY PORCH w/ FLAT ROOF

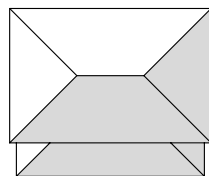

E. FULL FRONT PORCH w/ HIPPED ROOF

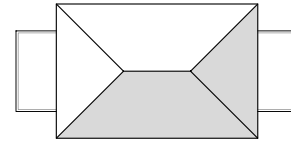

F. SIDE WINGS w/ FLAT ROOF

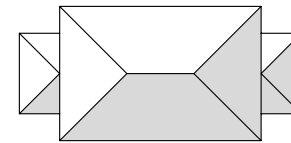

G. SIDE WINGS w/ HIPPED ROOF

1. MATERIALS:

- smooth sawn wood shingles, NOT split shakes.
- flat profile ("slate") concrete tiles; approved colours only.
- natural slate, copper, zinc.
- asphalt shingles; approved styles and colours only.

2. SLOPE:

- 8:12 MIN.; steeper slopes are encouraged.

3. The eave shall overhang 12" MAX.

4. The eave shall overhang 12" MAX. on gable ends.

5. Parapet walls shall extend 8" MIN. - 12" MAX. above the roof.

6. Parapet walls shall be 8" MIN. - 12" MAX. thick when visible from the street.

7. The fascia board shall be 8" MIN. - 12" MAX.

8. Bargeboard on gable ends shall be 8" MIN. - 12" MAX.

9. Smaller houses are encouraged to have side gable roofs.

© 1998, Jenkins & Associates Architecture and Town Planning Ltd.

Section

I. Building Form

Drawing Name

ROOFS

Drawing No.

2.05



February 2007

A. FULL FRONT PORCH w/ FLAT ROOF

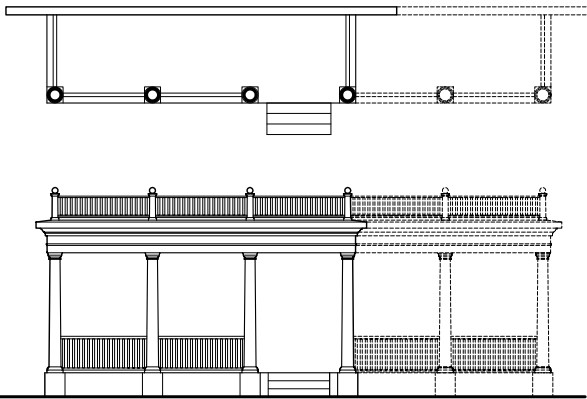

B. FULL FRONT PORCH w/ DOUBLE COLUMNS & HIPPED ROOF

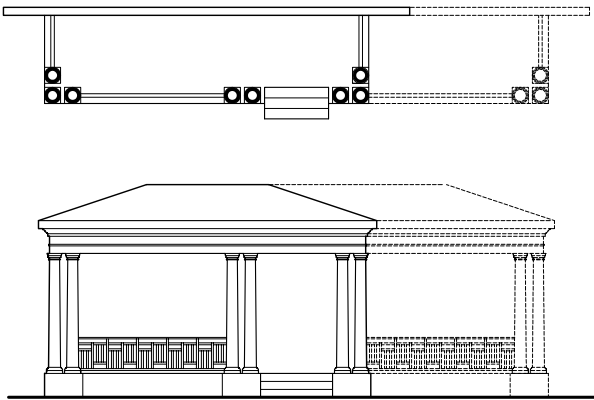

C. FULL FRONT PORCH w/ GABLED PEDIMENT OVER ENTRY

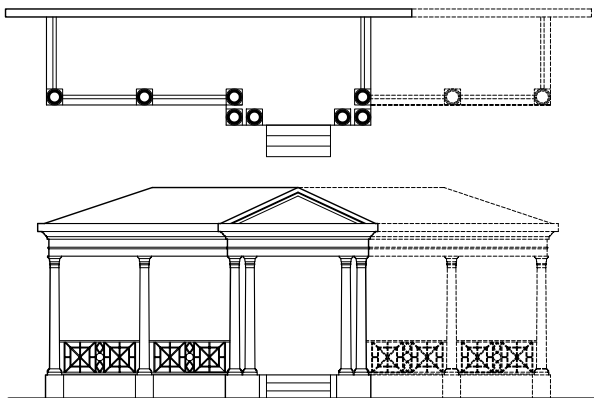

1. MATERIALS:
  - concrete faced in brick or stone is encouraged.
  - wood, painted.
  - pediment/cornice/frieze may be approved pre-manufactured casts or moulds.
  - Smart Trim
2. Flat or pent (hipped) roofs ONLY are permitted on porches.
3. Roofs over porches may have a slope of 6:12 MIN. - 8:12 MAX.
4. Porches are to be one-storey to the eave MAX.
5. Porches shall be 36 sq.ft. MIN. in area.
6. Porches shall be symmetrically organized on elevations of 5-bays or greater.
7. Porches may be used where there are bays.
8. A 12" MIN. entablature is required, and is typically detailed in a similar manner to the eave details of the house.
9. Brackets are not permitted on Colonial houses.
10. Porches are typically organized with an odd number of bays and an even number of columns.

© 1998, Jenkins & Associates Architecture and Town Planning Ltd.

Section

II. Building Elements

Drawing Name

PORCHES

Drawing No.

2.06



February 2007

## STOOPS WITH COLUMNS

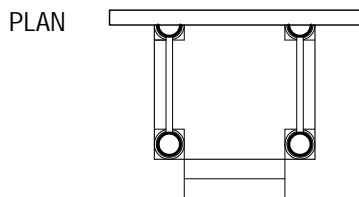
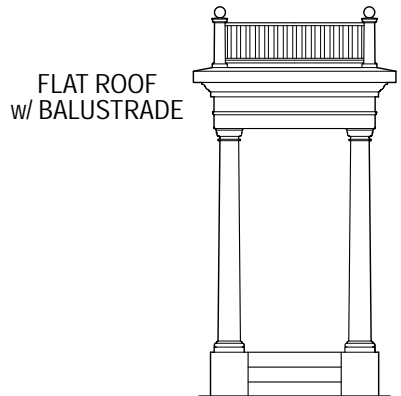
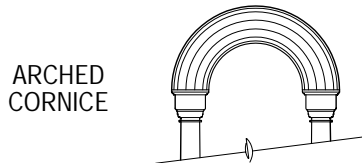

## FLUSH ENTRIES WITH PILASTERS

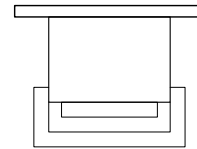
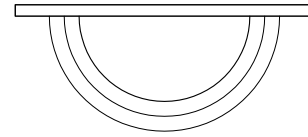

PLAN

1. Stoops may or may not have canopies.
2. MATERIALS: Steps  
- concrete; faced in brick or stone is encouraged.
3. MATERIALS: Stoop  
- wood; painted (see Materials Code for approved alternatives for wood).  
- approved pre-manufactured casts or moulds.
4. All pediments and cornices are to be finished with trim.
5. Refer to 1.08 for approved DOOR SURROUNDS.

© 1998, Jenkins & Associates Architecture and Town Planning Ltd.

Section

## II. Building Elements

Drawing Name

# ENTRY PORCHES & STOOPS

Drawing No.

# 2.07



February 2007

## UPPER FLOORS

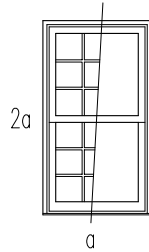

## MAIN FLOOR

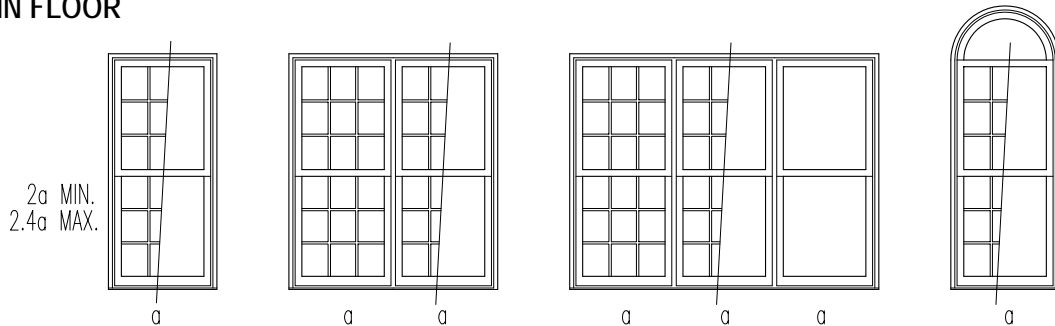

1. **MATERIALS: Windows**
  - wood; painted, stained, or clad.
  - some vinyl styles with prior approval ONLY.
2. Upper floor windows are to have a proportion of:  
 $2a : a$  ONLY.
3. Main floor windows are to have a proportion of:  
 $2a : a$  TO  $2.4a : a$ .
4. Windows are typically five-ranked and symmetrically balanced with a central door.
  - Less commonly three-ranked and seven-ranked.
5. Ganged windows are not permitted above the main floor.
6. Transoms are permitted on main floor windows ONLY.
7. Muntin bars are to be 3/4" MIN. in thickness.
8. Muntin bars are encouraged to be placed on both the outside and inside of window glazing. However, muntin bars may be placed inside sealed units or, at a MIN., on the outside of the window glazing.
9. **MATERIALS: Muntin Bars**
  - wood; painted, stained, or clad
  - some vinyl styles with prior approval ONLY.
10. A 9 pattern grid is encouraged in each window pane.

© 1998, Jenkins & Associates Architecture and Town Planning Ltd.

Section

## II. Building Elements

Drawing Name

# WINDOW TYPES

Drawing No.

# 2.08



February 2007



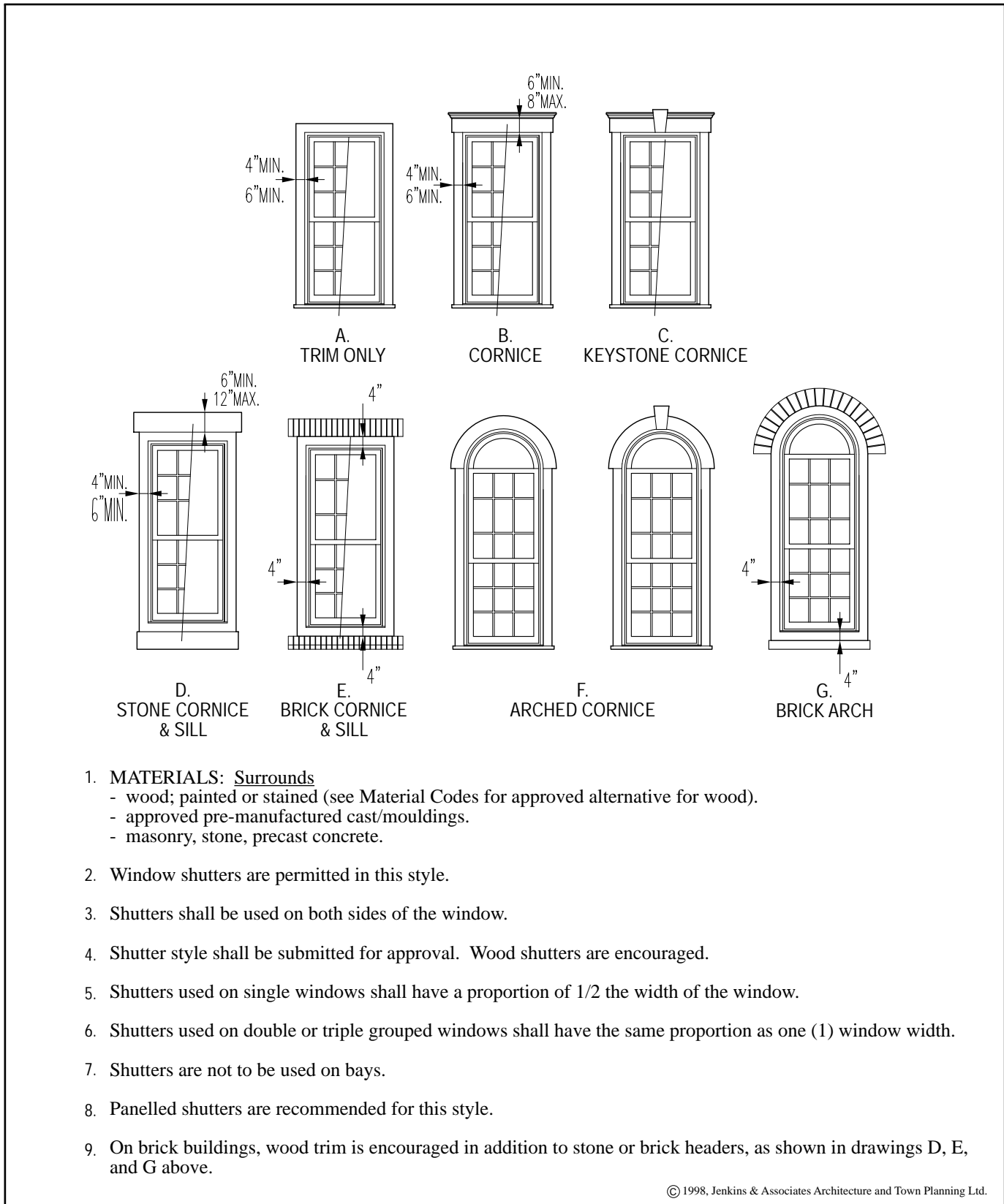

Section  
**II. Building Elements**  
 Drawing Name  
**WINDOW SURROUNDS**

Drawing No.  
**2.09**



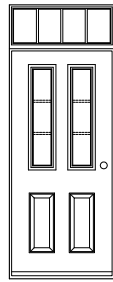

RECTANGULAR  
TRANSOM

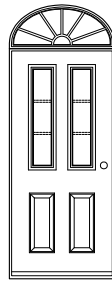

ELLIPTICAL  
TRANSOM

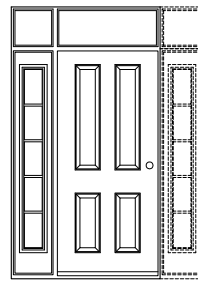

RECT. TRANSOM  
w/ SIDELIGHT

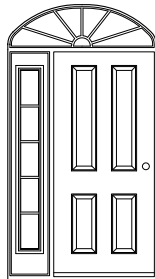

ELLIPTICAL TRANSOM  
w/ SIDELIGHTS

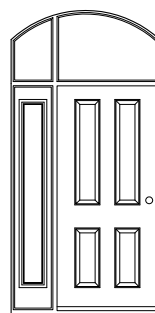
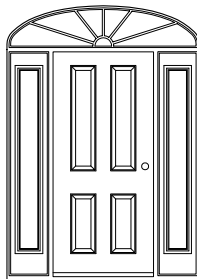

EXTENDED ELLIPTICAL  
TRANSOM w/ SIDELIGHTS

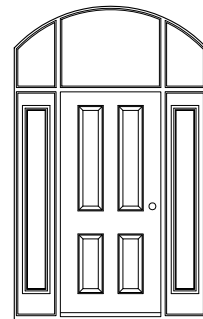

1. MATERIALS: Doors
  - wood; painted, stained, or clad.
  - insulated, panelled metal doors.
2. Door panel configurations may vary from those shown above.
3. Double sidelights, double sidelight with transoms, are permitted on symmetrically organized elevations ONLY.
4. Single sidelight, double sidelight with transom, are permitted with prior approval only.
5. Glazed panels are recommended where there is no sidelight or transom.

© 1998, Jenkins & Associates Architecture and Town Planning Ltd.

Section

II. Building Elements

Drawing Name

DOOR TYPES

Drawing No.

2.10



February 2007

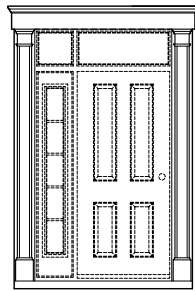

CORNICE  
w/ Side Pilasters

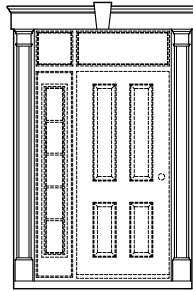

KEYSTONE CORNICE  
w/ Pilasters

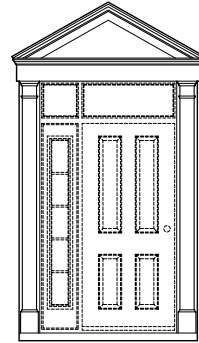

PEDIMENT  
w/ Pilasters

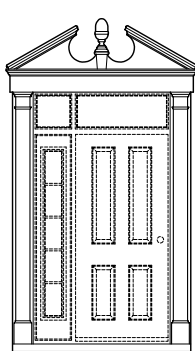

BROKEN PEDIMENT  
w/ Pilasters

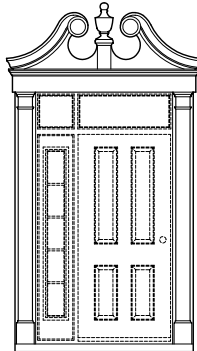

RAMSHORN PEDIMENT  
w/ Pilasters

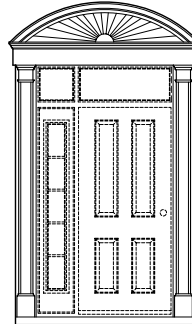

SUNBURST PEDIMENT  
w/ Pilasters

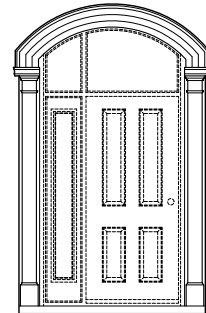

ARCHED CORNICE  
w/ Pilasters

1. **MATERIALS: Surrounds**
  - wood; painted or stained.
  - approved pre-manufactured cast/mouldings.
  - aluminum or vinyl surrounds are NOT permitted.
2. Door panel configurations may vary from those shown above.
3. All surround styles may apply to all door and transom configurations.
4. Where there are PORCHES or ENTRY PORCHES, the door surround shall be 4" MIN. - 10" MAX. trim board ONLY, with no cornice or pediment.
5. Where there is a pediment, there shall always be side pilasters.
6. Where there are no pilasters below a cornice, the trim below the cornice shall be 6" MIN. - 10" MAX..

© 1998, Jenkins & Associates Architecture and Town Planning Ltd.

Section

## II. Building Elements

Drawing Name

# DOOR SURROUNDS

Drawing No.

# 2.11



February 2007

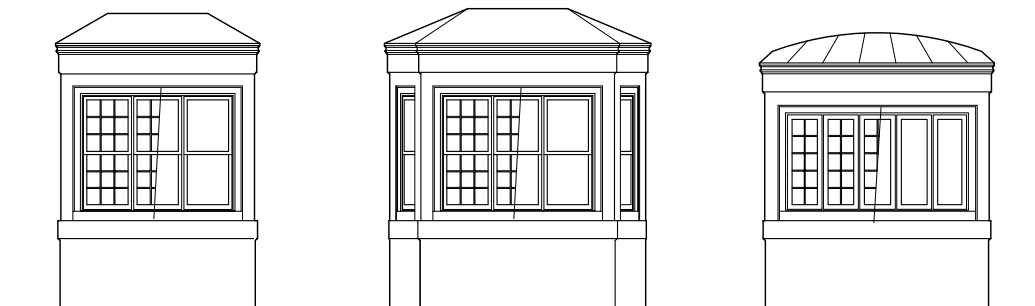

SQUARE  
BAY



FACETED  
BAY



BOW  
BAY

1. MATERIALS: Base
  - shall be of stone or brick.
  - panelled wood; painted or stained.
  - Crezone panels, Smart Trim.
2. MATERIALS: Roof
  - natural zinc or copper.
  - composite zinc or copper.
  - approved asphalt or fibreglass architectural shingles.
3. Cantilevered bays are NOT permitted.
4. Bays are to be one-storey MAX. in height.
5. Roof slopes over bays may be 6:12 MIN.
6. Shed roofs are NOT permitted on bays.
7. The wall between windows in a bay are to be wood trim and/or wood panelling. Brick, masonry, or stone will not be permitted. Cement fibre and prefinished hardboard trim will be permitted.
8. Bays are not permitted above the first storey.

© 1998, Jenkins & Associates Architecture and Town Planning Ltd.

Section

## II. Building Elements

Drawing Name

# BAYS

Drawing No.

# 2.12



February 2007

## TRADITIONAL DORMER EXAMPLES

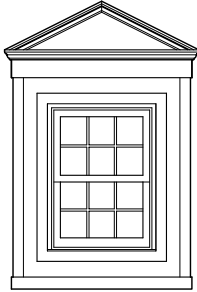

GABLED  
PEDIMENT

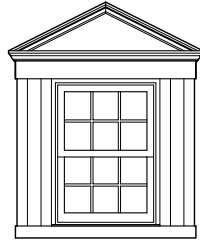

GABLED  
PEDIMENT

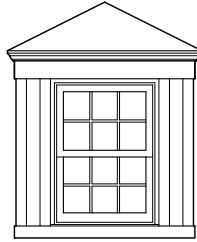

HIPPED

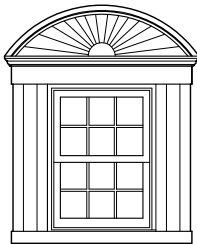

SUNBURST  
PEDIMENT

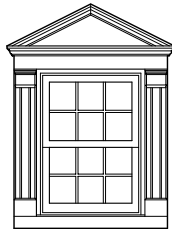

all types w/  
SIDE PILASTERS

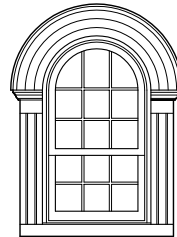

ARCHED  
CORNICE

## TRADITIONAL DORMER WINDOW PROPORTIONS

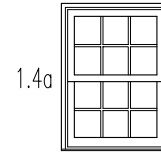

1.4a

a

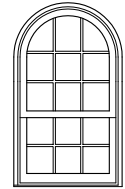

1. **MATERIALS:** Windows
  - wood; painted, stained, or clad.
  - some vinyl styles, with prior approval only.
2. Muntin bars are to be used consistently with the other windows of the front elevation.
3. Wood finishes **ONLY** are permitted in Gable Pediment dormers (see Materials Code for approved alternatives for wood).
4. Sides of all dormers are to be wood siding, wood fibre siding, fibre cement siding, or approved vinyl siding.
5. The distance between the edge of the dormer and the window shall be 12" MIN. - 18" MAX.
6. All dormer types may use pilasters flanking the window.
7. The cornice board above the window shall be 12" MIN.
8. Ganged windows forms in dormers are not permitted in this style.
9. Dormers are to have corner boards and trim at the windows.

© 1998, Jenkins & Associates Architecture and Town Planning Ltd.

Section

## II. Building Elements

Drawing Name

# DORMERS

Drawing No.

# 2.13



February 2007

## TRADITIONAL EXAMPLES

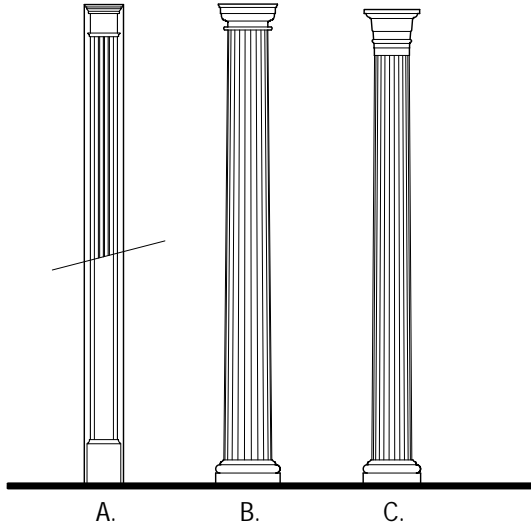

CLASSICAL COLUMNS

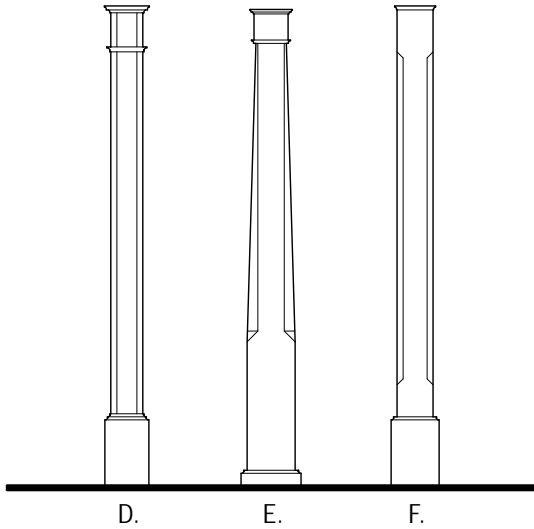

VERNACULAR COLUMNS

1. **MATERIALS:** Columns
  - wood; painted.
  - stone, concrete.
  - preformed glass fibre casts will be permitted with prior approval **ONLY**.
2. Aluminum columns or pilasters are **NOT** encouraged.
3. Columns and pilasters may be fluted or unfluted.
4. Columns and pilasters are to have a proportion of 1:8 (width:height).
5. Pilasters shall be 10" MIN. wide when they are applied as door surrounds.
6. Pilasters shall be 12" MIN. wide where they are applied to the building elevation.
7. Pilasters may be applied to the elevation as corner details.
8. Pilasters may be placed between window bays.
9. Pilasters shall extend the full height of the wall to the underside of the trim at the top of the wall.

- A. PILASTER  
 B. DORIC  
 C. TUSCAN  
 D. SQUARE  
 E. TAPERED BOX  
 F. CHAMFERED BOX

© 1998, Jenkins & Associates Architecture and Town Planning Ltd.

Section

II. Building Elements

Drawing Name

**COLUMNS**

Drawing No.

**2.14**



February 2007

## TRADITIONAL BALUSTRADE EXAMPLES

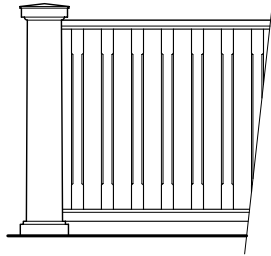

A.

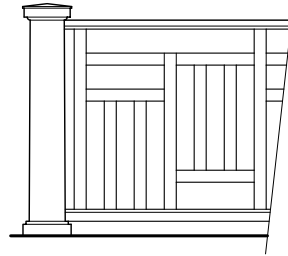

B.

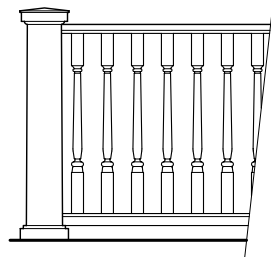

C.

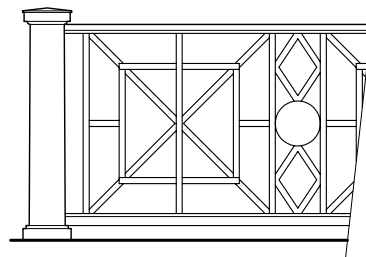

D.

- A. Top and bottom wood rails with 2x2 CHAMFERED SQUARE balusters.
- B. Top and bottom wood rails with 2x2 SQUARE balusters in traditional Colonial pattern.
- C. Top and bottom wood rails with 2" dia. wood SPINDLES.
- D. Top and bottom wood rails with 1" dia. metal COLONIAL CROSS pattern.

- 1. MATERIALS: Wood top and bottom rails with wood balusters; painted or stained.
- 2. MATERIALS: Wood top and bottom rails with steel balusters; painted.
- 3. Wood balusters shall be 2" x 2".
- 4. Wood spindles shall be 2" dia. MIN.
- 5. Metal balusters shall be MIN. 3/4" dia.; painted.
- 6. Newel posts, where required, shall be 8" x 8" MIN.
- 7. Top and bottom rails shall be 2" x 4" MIN., 2" x 6" recommended.

© 1998, Jenkins & Associates Architecture and Town Planning Ltd.

Section

II. Building Elements

Drawing Name

**BALUSTRADES**

Drawing No.

**2.15**



February 2007

## APPROVED EAVE DETAILS

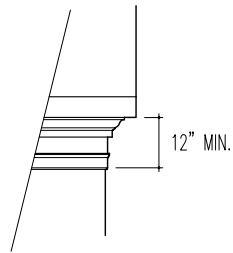

A.  
FRIEZE &  
CORNICE 1

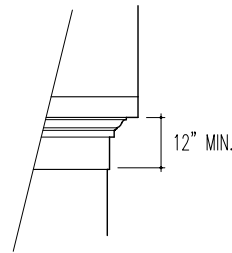

B.  
FRIEZE &  
CORNICE 2

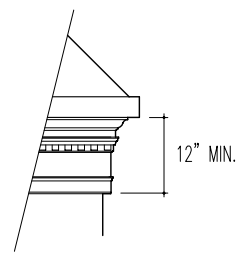

C.  
DENTIL BLOCK FRIEZE &  
EXPANDED CORNICE

1. **MATERIALS:** Eave Detailing
  - wood; painted.
  - approved pre-manufactured mouldings or casts.
2. Dentil block trim or similar detailing is to occur **ONLY** where there is an eave.

**Photo Credits:**

P. 2.01 Baker, William T. New Classicists, Victoria, The Images Publishing Group Pty Ltd., 2004, p.319

P. 2.03 Lockwood, Charles. Bricks and Brownstone: The New York Row House 1783-1929, New York, Rizzoli International Publications, 2003, p. CP6

© 1998, Jenkins & Associates Architecture and Town Planning Ltd.

Section

III. Details

Drawing Name

EAVE DETAILS

Drawing No.

2.16



February 2007



# THE DIOCESE PROPERTY

## *Colonial Style Materials & Colour Codes*

The intent of the 'Colonial Style' Materials and Colour Specifications are to assist the builders in identifying materials and colours suitable for Colonial Style buildings in the Diocese Property. The approved materials and colours are the result of research of Colonial Style buildings particular to the City of Regina. It is the combination of architectural style, and the appropriate materials and colours to the Colonial Style that results in a historically accurate representation for the Diocese Property neighbourhood.

Colonial Style buildings typically are brick or siding,. Windows and trim are typically white or off-white. Shutters and front doors are usually stained wood, or are painted in a high-gloss black, dark green, or red. When using brick, rumbled bricks with a ½" slightly tooled mortar joint are most common. Beveled horizontal siding is the most common wall cladding seen in this style.

Using the Diocese Property Codes:

- The Diocese Property Architectural Codes define approved materials for Colonial Style buildings and where the materials may be used.
- The Materials Matrix defines the type and manufacturer of approved materials for Colonial Style buildings.
- The Colour Matrix defines approved paint and stain colours for Colonial Style buildings.
- The Materials & Colours Specifications printed in colour, are intended to act as a visual guide to the matrices noted above.

It is essential to use all Code references **concurrently** to provide a comprehensive understanding of the style. This is the intent of the Diocese Property Codes.

**ROOFING:** ● APPROVED ○ NOT APPROVED

DESCRIPTION	MANUFACTURER	CODE/MATERIAL	SIZE	WARRANTY	COLOUR	COLONIAL	COMMENTS
ASPHALT SHINGLES	BP	ECLIPSE	N/A	LIFETIME	TWILIGHT GREY	●	
					STONEWOOD	○	
					WEATHERED ROCK	○	
					SHADOW BLACK	●	
					AUTUMN BROWN	○	
	IKO INDUSTRIES LTD.	CHATEAU	N/A	30 YEAR	HARVARD SLATE	●	
					WEATHERWOOD	○	
					DUAL BLACK	●	
					FOREST GREEN	●	
FIBREGLASS SHINGLES	BP	HARMONY	N/A	30 YEAR	TWILIGHT GREY	●	
					STONEWOOD	○	
					WEATHERED ROCK	○	
					SHADOW BLACK	●	
					AUTUMN BROWN	○	
	IKO INDUSTRIES LTD.	CAMBRIDGE	N/A	25 YEAR	HARVARD SLATE ULTRA	●	
					WEATHERWOOD ULTRA	○	
					DUAL BLACK ULTRA	●	
					FOREST GREEN ULTRA	●	
	TIMBERLINE	TIMBERLINE 35	N/A	35 YEAR	CHARCOAL BLEND	●	
					MISSION BROWN BLEND	○	
					PEWTER GRAY BLEND	●	
	ELK PREMIUM ROOFING	PRESTIQUE	N/A	30 YEAR	ANTIQUÉ SLATE	●	
					WEATHERWOOD	○	
					SABLEWOOD	●	
					FOREST GREEN	●	
CONCRETE TILE	UNICRETE PRODUCTS LTD.	3A (SLATE - STANDARD PROFILE)	N/A	N/A	NEW BARK 0342	●	PERMITTED ON BUILDINGS WITH MIN. 50 FT. FRONTAGE
CONCRETE TILE	UNICRETE PRODUCTS LTD.	3A (SLATE - STANDARD PROFILE)	N/A	N/A	PARAMOUNT MOSS 0354	●	
CEMBRIT SLATE	UNICRETE PRODUCTS LTD.	DIAGONAL SLATE	400 X 400mm	N/A	BLACK	●	
CEMBRIT SLATE	UNICRETE PRODUCTS LTD.	DIAGONAL SLATE	600 X 600mm	N/A	BLACK	●	
NATURAL SLATE	UNIVERSAL SLATE INT.	SEMI-GAUGED	30 X 15cm	N/A	SUBMIT FOR APPROVAL	●	
NATURAL SLATE	UNIVERSAL SLATE INT.	SEMI-GAUGED	30 X 20cm	N/A	SUBMIT FOR APPROVAL	●	
NATURAL COPPER	SUBMIT FOR APPROVAL	N/A	N/A	N/A	N/A	●	
NATURAL ZINC	SUBMIT FOR APPROVAL	N/A	N/A	N/A	N/A	●	
CEDAR SHINGLES	SUBMIT FOR APPROVAL	N/A	N/A	N/A	REFER TO COLOR SCHEDULE	○	

**DIOCESE  
PROPERTY  
ARCHITECTURAL  
GUIDELINES**

**MATERIALS &  
COLOURS  
MATRIX**

**COLONIAL  
STYLE**

M1

**FEBRUARY 2007**

The Owner reserves the right to adjust the guidelines as necessary. All materials must be submitted to the Site Architect for conformity to all standards. These Guidelines are to be adhered to in addition to requirements of the Master Site Plan. Any use of the exclusive property of JENKINS & ASSOCIATES ARCHITECTURE and TOWNPLANNING LTD. and may be reproduced only with the permission of the Architect in which case the reproduction must bear the name of the Architect. This drawing is not to be scaled. This drawing is to serve as a guideline ONLY.



**JENKINS & ASSOCIATES  
ARCHITECTURE AND TOWN PLANNING LTD.**

CALGARY ALBERTA CANADA



**WALL CLADDING:**

● APPROVED ○ NOT APPROVED

DESCRIPTION	MANUFACTURER	CODE/MATERIAL	SIZE	COLOUR	COLONIAL	COMMENTS
HORIZONTAL VINYL SIDING	MITTEN VINYL INC.	OREGON PRIDE	D4.5 HORIZ.	FROST CLAY	○	
				BONE WHITE	○	
				ASH	○	
				SANDALWOOD	○	
	GENTEK BUILDING PRODUCTS	CONCORD	D4 / T3	SNOW WHITE	○	
				CANYON CLAY	○	
				LINEN	○	
				WICKER	○	
				ALMOND	○	
				ANTIQUÉ IVORY	○	
				MAIZE	○	
				WHITE	○	
	ROYAL BUILDING PRODUCTS	ROYAL WOODLAND	DOUBLE 4 1/2	CLAY	○	
			TRADITIONAL	LINEN	○	
				SAND	○	
				BEIGE	○	
				WHITE	○	
		ARCHITECTURAL SERIES	DOUBLE 4 1/2	CLAY	○	
			TRIPLE 3 (T3D)	LINEN	○	
				WICKER	○	
				SAND	○	
				BEIGE	○	
FIBRE CEMENT SIDING	JAMES HARDIE	HARDIPLANK	5" EXPOSURE	ARCTIC WHITE	●	
			SMOOTH	NAVAJO WHITE	●	
				MONTEREY GRAY	●	
				COLONIAL GRAY	○	
				SKY GRAY	○	
				KHAKI BROWN	○	
				REDWOOD	○	
				NAVAJO BEIGE	●	
				MONTEREY TAUPE	●	
				SANDSTONE BEIGE	●	
				WOODLAND CREAM	●	
				AUTUMN TAN	●	
				COBBLE STONE	●	

**DMCESE  
PROPERTY  
ARCHITECTURAL  
GUIDELINES**

**MATERIALS &  
COLOURS  
MATRIX**

**COLONIAL  
STYLE**

M3

**FEBRUARY 2007**

The Owner reserves the right to adjust the guidelines as necessary. All building plans and elevations must be approved by the City of Calgary, as all materials and colours must be approved in addition to requirements of the Master Site Plan.  
This drawing is the exclusive property of JENKINS & ASSOCIATES ARCHITECTURE AND TOWN PLANNING LTD. and may be reproduced only with the permission of the Architect. In case the reproduction must bear the name of the Architect.  
This drawing is not to be scaled. This drawing is to serve as a guideline ONLY.

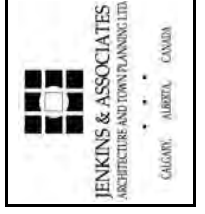





**WINDOWS AND DOORS:** ● APPROVED ○ NOT APPROVED

DESCRIPTION	MANUFACTURER	CODE / MATERIAL	SIZE	COLOUR	COMMENTS
METAL CLAD UNITS	SUBMIT FOR APPROVAL	N/A	REFER TO ARCH. CODES	REFER TO COLOUR SCHEDULE	●
	ALL WEATHER WINDOWS	N/A	REFER TO ARCH. CODES	WICKER	○
		→		ARCHITECTURAL BROWN	○
	CWD	N/A		CHOCOLATE BROWN	○
		→		SANDLEWOOD	○
		→		BRONZE METALLIC	○
PVC UNITS	SUBMIT FOR APPROVAL	N/A	REFER TO ARCH. CODES	REFER TO COLOUR SCHEDULE	●
	ALL WEATHER WINDOWS	→		WICKER	○
	CWD	N/A		SANDLEWOOD	○
WOOD UNITS	SUBMIT FOR APPROVAL	N/A	REFER TO ARCH. CODES	REFER TO COLOUR SCHEDULE	●

**EXTERIOR DETAILING:** ● APPROVED ○ NOT APPROVED

DESCRIPTION	MANUFACTURER	CODE / MATERIAL	SIZE	COLOUR	COMMENTS
SHUTTERS	SUBMIT FOR APPROVAL	N/A	REFER TO ARCH. CODES	REFER TO COLOUR SCHEDULE	●
TRIM	N/A	ROUGH OR SMOOTH SAWN WOOD*	REFER TO ARCH. CODES	REFER TO COLOUR SCHEDULE	●
TRIM	SMARTSYSTEM/JAMES HARDIE	SMART TRIM/HARDIETRIM	REFER TO ARCH. CODES	REFER TO COLOUR SCHEDULE	●
CORNICE, FRIEZE DETAILS, SILL, HEADER	SUBMIT FOR APPROVAL	WOOD, MOLDED POLY	REFER TO ARCH. CODE	REFER TO COLOUR SCHEDULE	●
CORNICE, FRIEZE DETAILS, SILL, HEADER	STONETILE (CANADA) LTD.	REINFORCED CAST CONC. MOULDING	REFER TO ARCH. CODE	SUBMIT FOR APPROVAL	OR APPROVED EQUAL
FASCIA	SUBMIT FOR APPROVAL	WOOD, ALUMINUM ONLY	REFER TO ARCH. CODE	REFER TO COLOUR SCHEDULE	●
SOFFITS	SUBMIT FOR APPROVAL	WOOD, ALUMINUM, OR VINYL	N/A	REFER TO COLOUR SCHEDULE	●
FASCIA / SOFFITS	GENTEK	ALUMINUM		NUTMEG	○
				SLATE	○
				SABLE	○
				BLACK	○
				ROYAL LINEN #902	●
				ROYAL CLAY #913	○
				ROYAL BEIGE #924	●
				REYNOLDS ROYAL LINEN #924	●
				REYNOLDS ROYAL CLAY #913	○
				REYNOLDS IVORY #302	○
CORNER BOARDS	N/A	WOOD, APPROVED VINYL	REFER TO ARCH. CODE	REFER TO COLOUR SCHEDULE	●
EAVESTROUGHS AND DOWNSPOUTS	N/A	ALUMINUM	STANDARD RESIDENTIAL	MATCH TO TRIM COLOURS	●
FENCING	SUBMIT FOR APPROVAL	WROUGHT IRON	REFER TO ARCH. CODES	BLACK ONLY	●
FENCING	SUBMIT FOR APPROVAL	WOOD	REFER TO ARCH. CODES	WHITE ONLY	●

\*UNLESS OTHERWISE SPECIFIED

**DIOCESAN PROPERTY ARCHITECTURAL GUIDELINES**

**MATERIALS & COLOURS MATRIX**

**COLONIAL STYLE**

**M6**

**FEBRUARY 2007**

The Owner reserves the right to adjust the guidelines as necessary. All building plans and elevations must be submitted to the Site Architect for conformity to all applicable guidelines. The Site Architect is not responsible for any errors or omissions in addition to requirements of the Master Site Plan. This drawing is the exclusive property of JENKINS & ASSOCIATES ARCHITECTURE and TOWN PLANNING LTD. No part of this drawing may be reproduced, stored in a retrieval system, or transmitted in any form or by any means, electronic, mechanical, photocopying, recording, or otherwise, without the prior written permission of the Architect. In case the reproduction must bear the name of the Architect. This drawing is not to be scaled. This drawing is to arrive as a printed ONLY.

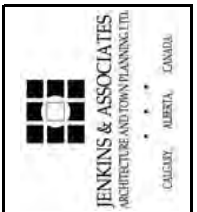





**COLOUR SCHEDULE:**

APPROVED  NOT APPROVED

MANUFAC-TURER	COLOUR (OLD #)	COLONIAL										COMMENTS			
		MAIN BODY OF HOUSE	TRIM	DOORS	WINDOWS	DOOR & WINDOW SURROUNDS	SHUTTERS	COLUMNS & BALUSTRADES	CORNICE & FRIEZE DETAILING	GABLE ENDS	SOFFITS AND FASCIA				
BENJAMIN MOORE	2142-30 (511)	<input type="radio"/>	<input type="radio"/>	<input type="radio"/>	<input type="radio"/>	<input type="radio"/>	<input type="radio"/>	<input type="radio"/>	<input type="radio"/>	<input type="radio"/>	<input type="radio"/>	<input type="radio"/>	<input type="radio"/>	<input type="radio"/>	
	2143-10 (517)	<input type="radio"/>	<input type="radio"/>	<input type="radio"/>	<input type="radio"/>	<input type="radio"/>	<input type="radio"/>	<input type="radio"/>	<input type="radio"/>	<input type="radio"/>	<input type="radio"/>	<input type="radio"/>	<input type="radio"/>	<input type="radio"/>	
	2143-20 (525)	<input type="radio"/>	<input type="radio"/>	<input type="radio"/>	<input type="radio"/>	<input type="radio"/>	<input type="radio"/>	<input type="radio"/>	<input type="radio"/>	<input type="radio"/>	<input type="radio"/>	<input type="radio"/>	<input type="radio"/>	<input type="radio"/>	
	HC-135 (644)	<input type="radio"/>	<input type="radio"/>	<input checked="" type="radio"/>	<input type="radio"/>	<input type="radio"/>	<input type="radio"/>	<input type="radio"/>	<input type="radio"/>	<input type="radio"/>	<input type="radio"/>	<input type="radio"/>	<input type="radio"/>	<input type="radio"/>	
	OC-120 (926)	<input checked="" type="radio"/>	<input type="radio"/>	<input type="radio"/>	<input type="radio"/>	<input type="radio"/>	<input type="radio"/>	<input type="radio"/>	<input type="radio"/>	<input type="radio"/>	<input type="radio"/>	<input type="radio"/>	<input type="radio"/>	<input type="radio"/>	
	OC-132 (927)	<input checked="" type="radio"/>	<input type="radio"/>	<input type="radio"/>	<input type="radio"/>	<input type="radio"/>	<input type="radio"/>	<input type="radio"/>	<input type="radio"/>	<input type="radio"/>	<input type="radio"/>	<input type="radio"/>	<input type="radio"/>	<input type="radio"/>	
	OC-108 (931)	<input checked="" type="radio"/>	<input type="radio"/>	<input type="radio"/>	<input type="radio"/>	<input type="radio"/>	<input type="radio"/>	<input type="radio"/>	<input type="radio"/>	<input type="radio"/>	<input type="radio"/>	<input type="radio"/>	<input type="radio"/>	<input type="radio"/>	
	OC-109 (932)	<input checked="" type="radio"/>	<input type="radio"/>	<input type="radio"/>	<input type="radio"/>	<input type="radio"/>	<input type="radio"/>	<input type="radio"/>	<input type="radio"/>	<input type="radio"/>	<input type="radio"/>	<input type="radio"/>	<input type="radio"/>	<input type="radio"/>	
	OC-130 (967)	<input checked="" type="radio"/>	<input type="radio"/>	<input type="radio"/>	<input type="radio"/>	<input type="radio"/>	<input type="radio"/>	<input type="radio"/>	<input type="radio"/>	<input type="radio"/>	<input type="radio"/>	<input type="radio"/>	<input type="radio"/>	<input type="radio"/>	
	HC-41 (1099)	<input type="radio"/>	<input type="radio"/>	<input type="radio"/>	<input type="radio"/>	<input type="radio"/>	<input type="radio"/>	<input type="radio"/>	<input type="radio"/>	<input type="radio"/>	<input type="radio"/>	<input type="radio"/>	<input type="radio"/>	<input type="radio"/>	
	CC-420 (1104)	<input type="radio"/>	<input type="radio"/>	<input type="radio"/>	<input type="radio"/>	<input type="radio"/>	<input type="radio"/>	<input type="radio"/>	<input type="radio"/>	<input type="radio"/>	<input type="radio"/>	<input type="radio"/>	<input type="radio"/>	<input type="radio"/>	
	2161-30 (1113)	<input type="radio"/>	<input type="radio"/>	<input type="radio"/>	<input type="radio"/>	<input type="radio"/>	<input type="radio"/>	<input type="radio"/>	<input type="radio"/>	<input type="radio"/>	<input type="radio"/>	<input type="radio"/>	<input type="radio"/>	<input type="radio"/>	
	2163-10 (1134)	<input type="radio"/>	<input type="radio"/>	<input type="radio"/>	<input type="radio"/>	<input type="radio"/>	<input type="radio"/>	<input type="radio"/>	<input type="radio"/>	<input type="radio"/>	<input type="radio"/>	<input type="radio"/>	<input type="radio"/>	<input type="radio"/>	
	HC-68 (1238)	<input type="radio"/>	<input type="radio"/>	<input type="radio"/>	<input type="radio"/>	<input type="radio"/>	<input type="radio"/>	<input type="radio"/>	<input type="radio"/>	<input type="radio"/>	<input type="radio"/>	<input type="radio"/>	<input type="radio"/>	<input type="radio"/>	
	2172-30 (1301)	<input type="radio"/>	<input type="radio"/>	<input type="radio"/>	<input type="radio"/>	<input type="radio"/>	<input type="radio"/>	<input type="radio"/>	<input type="radio"/>	<input type="radio"/>	<input type="radio"/>	<input type="radio"/>	<input type="radio"/>	<input type="radio"/>	
	HC-108 (1487)	<input type="radio"/>	<input type="radio"/>	<input type="radio"/>	<input type="radio"/>	<input type="radio"/>	<input type="radio"/>	<input type="radio"/>	<input type="radio"/>	<input type="radio"/>	<input type="radio"/>	<input type="radio"/>	<input type="radio"/>	<input type="radio"/>	
	HC-107 (1488)	<input type="radio"/>	<input type="radio"/>	<input type="radio"/>	<input type="radio"/>	<input type="radio"/>	<input type="radio"/>	<input type="radio"/>	<input type="radio"/>	<input type="radio"/>	<input type="radio"/>	<input type="radio"/>	<input type="radio"/>	<input type="radio"/>	
	HC-100 (1489)	<input type="radio"/>	<input type="radio"/>	<input type="radio"/>	<input type="radio"/>	<input type="radio"/>	<input type="radio"/>	<input type="radio"/>	<input type="radio"/>	<input type="radio"/>	<input type="radio"/>	<input type="radio"/>	<input type="radio"/>	<input type="radio"/>	
2142-30 (1526)	<input type="radio"/>	<input type="radio"/>	<input type="radio"/>	<input type="radio"/>	<input type="radio"/>	<input type="radio"/>	<input type="radio"/>	<input type="radio"/>	<input type="radio"/>	<input type="radio"/>	<input type="radio"/>	<input type="radio"/>	<input type="radio"/>		
2137-30 (1540)	<input type="radio"/>	<input type="radio"/>	<input type="radio"/>	<input type="radio"/>	<input type="radio"/>	<input type="radio"/>	<input type="radio"/>	<input type="radio"/>	<input type="radio"/>	<input type="radio"/>	<input type="radio"/>	<input type="radio"/>	<input type="radio"/>		
R-9984 (1582)	<input type="radio"/>	<input type="radio"/>	<input checked="" type="radio"/>	<input type="radio"/>	<input type="radio"/>	<input type="radio"/>	<input type="radio"/>	<input type="radio"/>	<input type="radio"/>	<input type="radio"/>	<input type="radio"/>	<input type="radio"/>	<input type="radio"/>		
WHITE	<input checked="" type="radio"/>	<input type="radio"/>	<input type="radio"/>	<input type="radio"/>	<input type="radio"/>	<input type="radio"/>	<input type="radio"/>	<input type="radio"/>	<input type="radio"/>	<input type="radio"/>	<input type="radio"/>	<input type="radio"/>	<input type="radio"/>		
BLACK	<input type="radio"/>	<input checked="" type="radio"/>	<input type="radio"/>	<input type="radio"/>	<input type="radio"/>	<input type="radio"/>	<input type="radio"/>	<input type="radio"/>	<input type="radio"/>	<input type="radio"/>	<input type="radio"/>	<input type="radio"/>	<input type="radio"/>		
704	<input type="radio"/>	<input type="radio"/>	<input checked="" type="radio"/>	<input type="radio"/>	<input type="radio"/>	<input type="radio"/>	<input type="radio"/>	<input type="radio"/>	<input type="radio"/>	<input type="radio"/>	<input type="radio"/>	<input type="radio"/>	<input type="radio"/>		
708	<input type="radio"/>	<input type="radio"/>	<input type="radio"/>	<input type="radio"/>	<input type="radio"/>	<input type="radio"/>	<input type="radio"/>	<input type="radio"/>	<input type="radio"/>	<input type="radio"/>	<input type="radio"/>	<input type="radio"/>	<input type="radio"/>		
710	<input type="radio"/>	<input type="radio"/>	<input type="radio"/>	<input type="radio"/>	<input type="radio"/>	<input type="radio"/>	<input type="radio"/>	<input type="radio"/>	<input type="radio"/>	<input type="radio"/>	<input type="radio"/>	<input type="radio"/>	<input type="radio"/>		
712	<input type="radio"/>	<input type="radio"/>	<input type="radio"/>	<input type="radio"/>	<input type="radio"/>	<input type="radio"/>	<input type="radio"/>	<input type="radio"/>	<input type="radio"/>	<input type="radio"/>	<input type="radio"/>	<input type="radio"/>	<input type="radio"/>		
720	<input type="radio"/>	<input type="radio"/>	<input type="radio"/>	<input type="radio"/>	<input type="radio"/>	<input type="radio"/>	<input type="radio"/>	<input type="radio"/>	<input type="radio"/>	<input type="radio"/>	<input type="radio"/>	<input type="radio"/>	<input type="radio"/>		
723	<input type="radio"/>	<input type="radio"/>	<input checked="" type="radio"/>	<input type="radio"/>	<input type="radio"/>	<input type="radio"/>	<input type="radio"/>	<input type="radio"/>	<input type="radio"/>	<input type="radio"/>	<input type="radio"/>	<input type="radio"/>	<input type="radio"/>		
724	<input type="radio"/>	<input type="radio"/>	<input checked="" type="radio"/>	<input type="radio"/>	<input type="radio"/>	<input type="radio"/>	<input type="radio"/>	<input type="radio"/>	<input type="radio"/>	<input type="radio"/>	<input type="radio"/>	<input type="radio"/>	<input type="radio"/>		
725	<input type="radio"/>	<input type="radio"/>	<input type="radio"/>	<input type="radio"/>	<input type="radio"/>	<input type="radio"/>	<input type="radio"/>	<input type="radio"/>	<input type="radio"/>	<input type="radio"/>	<input type="radio"/>	<input type="radio"/>	<input type="radio"/>		
728	<input type="radio"/>	<input type="radio"/>	<input checked="" type="radio"/>	<input type="radio"/>	<input type="radio"/>	<input type="radio"/>	<input type="radio"/>	<input type="radio"/>	<input type="radio"/>	<input type="radio"/>	<input type="radio"/>	<input type="radio"/>	<input type="radio"/>		
CANDY APPLE	<input type="radio"/>	<input type="radio"/>	<input checked="" type="radio"/>	<input type="radio"/>	<input type="radio"/>	<input type="radio"/>	<input type="radio"/>	<input type="radio"/>	<input type="radio"/>	<input type="radio"/>	<input type="radio"/>	<input type="radio"/>	<input type="radio"/>		
TEAL	<input type="radio"/>	<input type="radio"/>	<input checked="" type="radio"/>	<input type="radio"/>	<input type="radio"/>	<input type="radio"/>	<input type="radio"/>	<input type="radio"/>	<input type="radio"/>	<input type="radio"/>	<input type="radio"/>	<input type="radio"/>	<input type="radio"/>		
BLACK BLACK	<input type="radio"/>	<input type="radio"/>	<input checked="" type="radio"/>	<input type="radio"/>	<input type="radio"/>	<input type="radio"/>	<input type="radio"/>	<input type="radio"/>	<input type="radio"/>	<input type="radio"/>	<input type="radio"/>	<input type="radio"/>	<input type="radio"/>		
5519	<input type="radio"/>	<input type="radio"/>	<input checked="" type="radio"/>	<input type="radio"/>	<input type="radio"/>	<input type="radio"/>	<input type="radio"/>	<input type="radio"/>	<input type="radio"/>	<input type="radio"/>	<input type="radio"/>	<input type="radio"/>	<input type="radio"/>		
5719	<input type="radio"/>	<input type="radio"/>	<input checked="" type="radio"/>	<input type="radio"/>	<input type="radio"/>	<input type="radio"/>	<input type="radio"/>	<input type="radio"/>	<input type="radio"/>	<input type="radio"/>	<input type="radio"/>	<input type="radio"/>	<input type="radio"/>		
6519	<input type="radio"/>	<input type="radio"/>	<input checked="" type="radio"/>	<input type="radio"/>	<input type="radio"/>	<input type="radio"/>	<input type="radio"/>	<input type="radio"/>	<input type="radio"/>	<input type="radio"/>	<input type="radio"/>	<input type="radio"/>	<input type="radio"/>		

DIOCESE PROPERTY ARCHITECTURAL GUIDELINES

COLONIAL MATRIX

COLONIAL STYLE

M8

MARCH 2003

The Owner reserves the right to adjust the building prices and elevations must be submitted to the Site Architect for conformity to all standards.

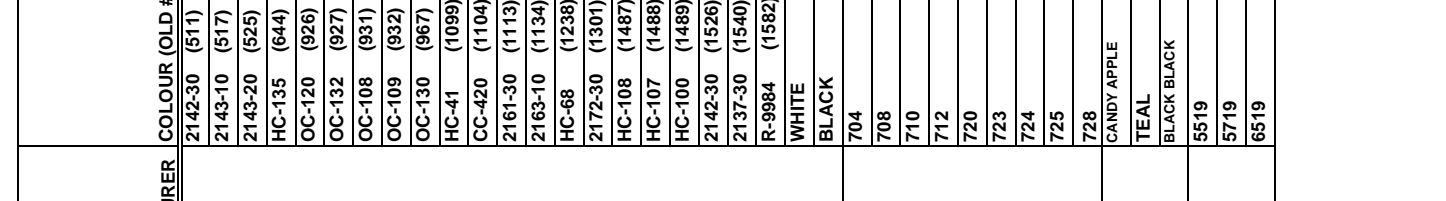

# DIOCESE PROPERTY



## ARCHITECTURAL CODES

3

## CRAFTSMAN STYLE

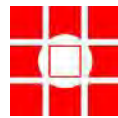

## *Craftsman Style Precedents*

Provided is a selection of photographic examples of buildings in the Craftsman style. These represent good examples of the Craftsman style for the Diocese Property.

The Craftsman style is characterized by low-pitched roofs accentuated by wide overhangs and exposed roof rafters. Upper floors typically feature dormers, which allow the roof to remain the dominant feature of the building.

Partial or full-width porches are usually supported by tapered square columns, although a variety of column configurations are used. The columns are usually extended to grade without a break at the porch level. The columns and plinths are usually massive in appearance; the tapering of porch sides and column piers emphasizes this. Also, the base material of the porch and column plinths is often a different material from the main body of the building. This divides the facade horizontally, emphasizing the grounded, solid appearance of the style. Decorative false beams or braces are often added in the gables.

The windows typically have geometric patterns of small pane glazing. The most common exterior cladding material is wood horizontal siding and shingles. Craftsman style colours are usually earth tones. Rich umbers, greens, and ochres can be found on traditional examples of this style.



**Craftsman buildings have porches, either full or partial width, with a roof supported by square columns.**

**Columns or column bases frequently continue to ground level (without a break at the level of the porch floor).**



**Extra stickwork is common in gables and porches.**

**Triangular knee braces under gables and porch roofs are common.**

© 1998, Jenkins & Associates Architecture and Town Planning Ltd.

Section

I. Building Form

Drawing Name

**HOUSE PRECEDENTS**

Drawing No.

**3.01**



February 2007



**Decorative (false) beams or braces under the eaves in the gable.**

**Windows are typically double hung with wooden muntins in upper sash.**

**Wall cladding in the gable is often different from the main body of the house.**



**Low-pitched gabled roofs with wide, unenclosed eave overhangs are common.**

**Rafter ends are commonly extended and/or elaborated.**

**Curved shape between porch supports is not uncommon.**

© 1998, Jenkins & Associates Architecture and Town Planning Ltd.

Section

I. Building Form

Drawing Name

HOUSE PRECEDENTS

Drawing No.

3.02



February 2007



**Multiple front gables.**

**Windows are usually ganged in groups of 3 or more.**

**A shed roof may be used to break up flat wall and gable.**

**Side gable roof with a prominent central dormer is a characteristic Craftsman feature.**



© 1998, Jenkins & Associates Architecture and Town Planning Ltd.

Section

**I. Building Form**

Drawing Name

**HOUSE PRECEDENTS**

Drawing No.

**3.03**



February 2007

## SIDE GABLE

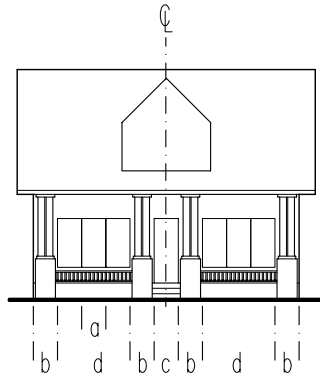

b = 12" MIN.

1. Windows in groups (gangs) of three or more are encouraged.
2. Dormers shall always be centered in the roof, or shall symmetrically appear centered above the window bays below.
3. The main roof shall extend to cover the porch.

## FRONT GABLE - *Single Gable*

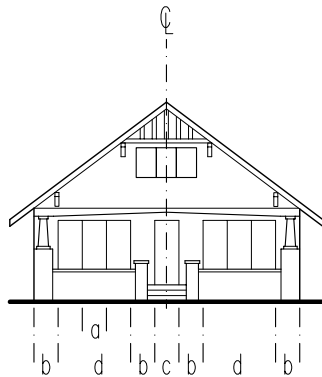

## - *Multiple Gables*

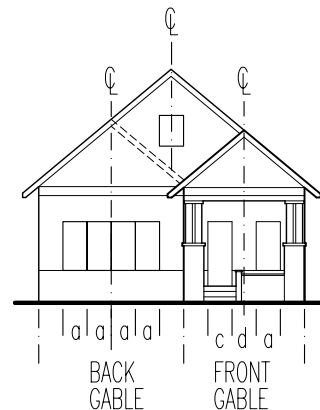

b = 12" MIN.

1. Windows in groups (gangs) of three or more are permitted in the BACK gable.
2. Windows in groups (gangs) of three or more ONLY are permitted in the SINGLE gable.
3. The main roof of the SINGLE gable shall extend to cover the porch.
4. The main roof of the FRONT gable shall extend to cover the entry porch.
5. Feature windows shall be centered in the gable end of the MULTIPLE form.
6. The BACK gable may or may not be used.

© 1998, Jenkins & Associates Architecture and Town Planning Ltd.

Section

I. Building Form

Drawing Name

**STREET ELEVATION**

Drawing No.

**3.04**



February 2007

## TWO STOREY

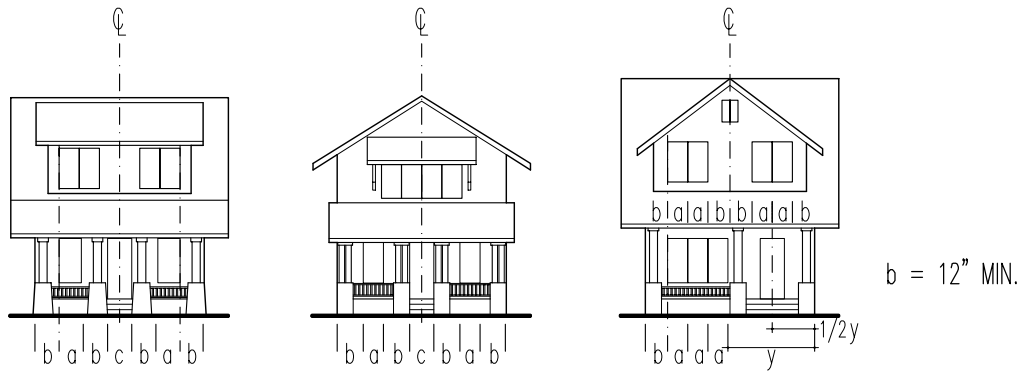

1. Roof forms may be either gabled or side gabled for all window / door configurations.
2. Dormers are encouraged in all side gabled roofs.
3. Feature windows may be used if they are centered in the elevation, and used at the second floor.
4. Porches shall always be used, and shall extend across the first floor only. Flat roofed porches will be permitted **ONLY** when the roof is used as a verandah for the second floor.

## CROSS GABLES

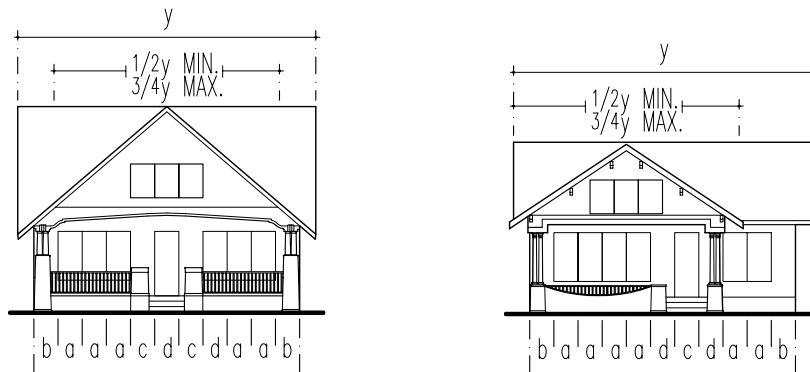

1. Windows in groups (gangs) of three or more are encouraged on the front elevation.
2. Entry door and window may be in either symmetrical or asymmetrical configurations on side cross gables. Symmetrical configurations may **ONLY** be used in Center Cross Gables.
3. The front gable forms the main roof over the porch, and is to extend  $1/2$  to  $2/3$  across the front elevation.
4. Feature windows in the front gable shall be centered in the gable.

© 1998, Jenkins & Associates Architecture and Town Planning Ltd.

Section

I. Building Form

Drawing Name

**STREET ELEVATION**

Drawing No.

**3.05**

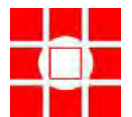

February 2007



## NARROW LOT TWO STOREY

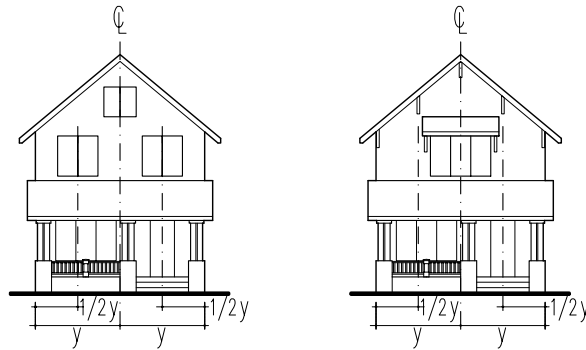

1. Roof forms are front gabled only.
2. Windows in groups (gangs) of three or more are encouraged on the front elevation.
3. Feature windows may be used if they are centered in the elevation, and used at the front gable.
4. Porches shall always be used, and shall extend across the first floor only. Flat roofed porches will be permitted ONLY when the roof is used as a verandah for the second floor.
5. A material change, separated by a continuous 8" MIN. trim board, is encouraged at the upper floor line, separating the main and upper floors, on all elevations.

© 1998, Jenkins & Associates Architecture and Town Planning Ltd.

Section

I. Building Form

Drawing Name

**STREET ELEVATION**

Drawing No.

**3.06**

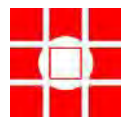

February 2007

TOWNHOUSE / MULTI-FAMILY

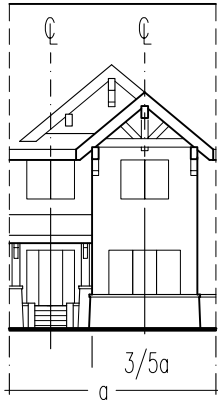

A.  
ENTRY PORCH  
w/ MULTIPLE GABLES



B.  
ENTRY PORCH  
w/ SINGLE GABLE

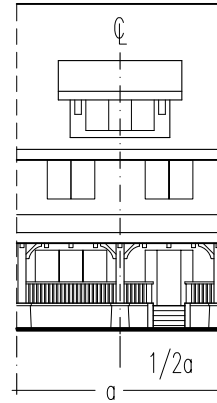

C.  
FULL PORCH  
w/ DORMER



D.  
ENTRY PORCH  
w/ MULTIPLE GABLES

1. Bays, ganged windows, and feature elements shall always be centered in the gable. In side gable elevations, dormers and windows shall be arranged symmetrically
2. Windows in groupings (gangs) of three or more are encouraged on the main floor.

© 1998, Jenkins & Associates Architecture and Town Planning Ltd.

Section

I. Building Form

Drawing Name

**STREET ELEVATION**

Drawing No.

**3.07**



February 2007

## STREET ELEVATION NOTES

1. MATERIALS: Main House
  - smooth stucco, spayed or sand finish, with wood trim.
  - horizontal bevelled wood siding.
  - wood fibre siding.
  - fibre cement siding.
  - wood shingles.
  - all materials in combination, with prior approval only.
2. Materials shall be the same over all elevations of the main body of the house.
3. MATERIALS: Rear & Sidewings
  - to be the same as the main body of the house.
4. MATERIALS: Building Base
  - a building base is required for this style.
  - stone is encouraged.
  - simulated stone (approval styles and colours ONLY).
  - cedar shingles.
5. HALF TIMBERING is not an uncommon detail in the Craftsman house, typically consisting of wood shingle, horizontal wood siding, or stucco between timber/wood patterning.
6. Craftsman Houses shall have a base of 12" MIN. - 60" MAX.
7. The base may taper away from the building at grade. This type of battered base is common in this style.
8. Porches and gables are the identifying features of this style. Porches most commonly appear as part of the main body of the house, and are sheltered by the main roof.
9. 6" or 8" trim boards may be used above the window continuously around the house. This detail is common and emphasizes the main roof and gables.
10. 4" or 6" corner boards are common in this style.
11. All trim shall be wood ONLY. See Materials Code for approved alternative materials for wood.

© 1998, Jenkins & Associates Architecture and Town Planning Ltd.

Section

I. Building Form

Drawing Name

STREET ELEVATION

Drawing No.

3.08



February 2007

## MAIN ROOF TYPES

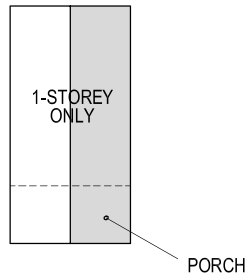

A. FRONT GABLE  
SIDE GABLE is also acceptable.

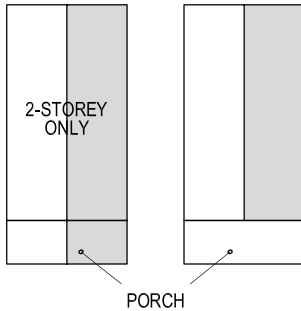

B. FRONT GABLE w/ PORCH

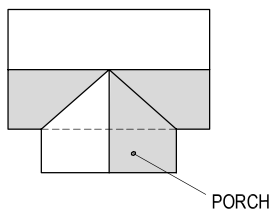

C. CENTER CROSS GABLE

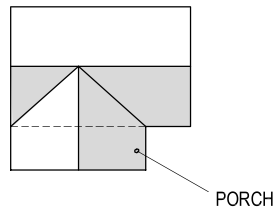

D. CROSS GABLE

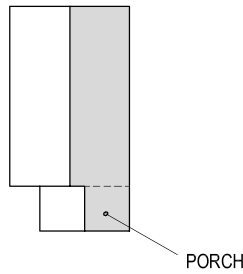

E. ENTRY PORCH GABLE

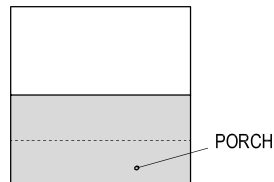

F. FULL FRONT PORCH  
under MAIN ROOF

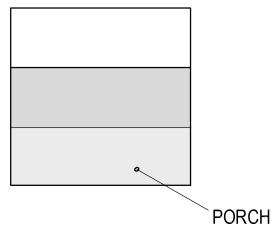

G. FLARED SHED ROOF over  
FULL FRONT PORCH

1. **MATERIALS:**
  - smooth sawn wood shingles. NOT split shakes.
  - asphalt shingles; approved styles and colours only.
2. **SLOPE:**
  - On gable roofs.  
6:12 MIN. to 12:12 MAX.
3. **SLOPE:**
  - On shed roofs and/or roofs over porches:  
4:12 MIN. to 10:12 MAX.
4. The eave shall overhang 24" MIN. - 36" MAX.
5. The eave shall overhang 24" MIN. - 36" MAX. on gable ends.
6. Parapeted gable ends are NOT permitted.
7. Rafters are to be exposed with no soffits.
8. The fascia board shall be 8" MIN. - 12" MAX.
9. The fascia board shall end as an exposed rafter end.
10. Bargeboard on gable ends shall be 8" MIN. - 12" MAX.

© 1998, Jenkins & Associates Architecture and Town Planning Ltd.

Section

I. Building Form

Drawing Name

ROOFS

Drawing No.

3.09



February 2007

## TRADITIONAL PORCH CONFIGURATIONS

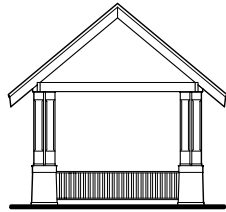

A.  
SIDE ENTRY, or  
FRONT ENTRY PORCH

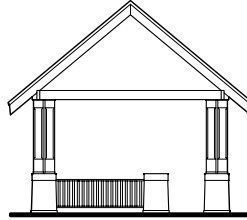

B.  
OFFSET ENTRY

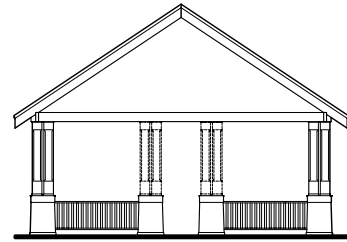

C.  
CENTER ENTRY

*All porch types may have SHED roof forms*

1. MATERIALS: Porch Floors
  - concrete faced in brick or stone.
  - wood.
2. MATERIALS: Roofs, Columns, Balustrades
  - as specified in respective sections.
3. MATERIALS: Gable Ends
  - as specified in GABLE ENDS.
4. Porches are to be one-storey to the eave MAX.
5. Roof slopes, overhangs, and fascia as specified in ROOFS.
6. Windows in gable ends of FRONT gable porches are typical of this style.
7. Gable window proportions shall conform to DORMER window proportions.
8. Gable end detailing shall conform to GABLE ENDS.
9. Porches shall have a usable depth of 5' MIN.
10. Porches shall have exposed rafters.
11. Brackets are encouraged on all porches.
12. Knee braces are encouraged to be used on all bays and gable ends.
13. Min. 2x4 material to be used on bracket and brace construction.
14. Beam and fascia together are to measure 10" MIN.

© 1998, Jenkins & Associates Architecture and Town Planning Ltd.

Section

### II. Building Elements

Drawing Name

## PORCHES

Drawing No.

# 3.10



February 2007

## FRONT GABLE

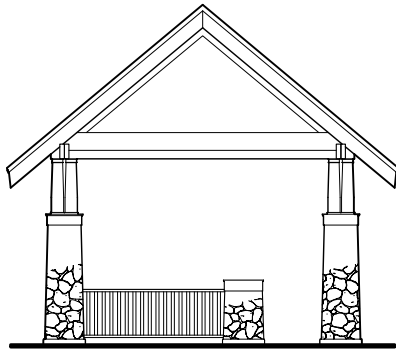

A. w/ PLAIN TRANSOM

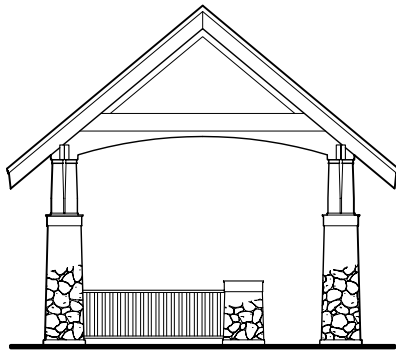

B. w/ SPRUNG TRANSOM

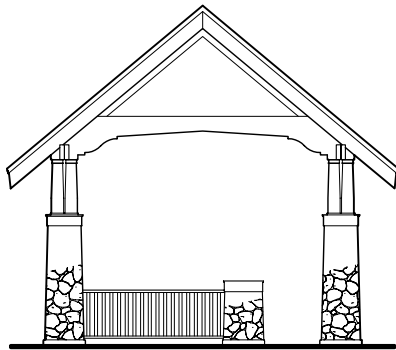

C. w/ ORNATE TRANSOM

## SIDE GABLE

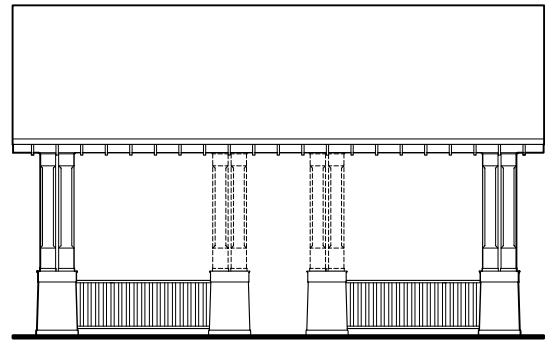

D. w/ PARTIALLY EXPOSED TRANSOM BEAM

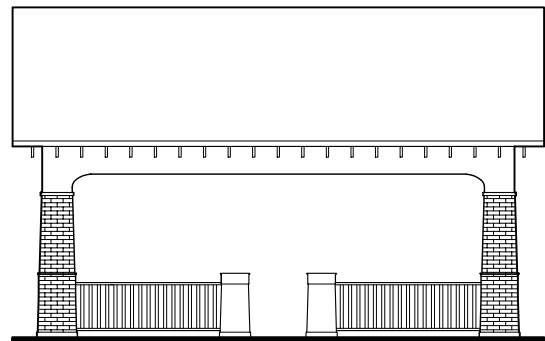

E. w/ BUILT-UP TRANSOM WALL  
Transom wall may be Ornate Transom Wall (as in 'C')

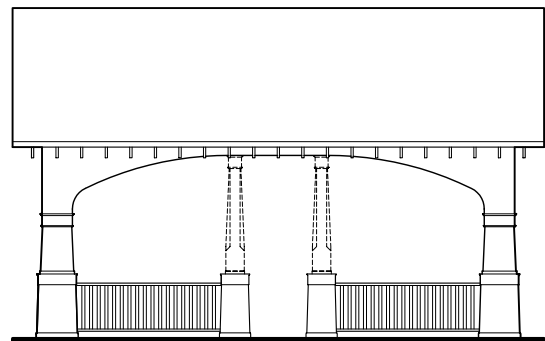

F. w/ SPRUNG TRANSOM and VERNACULAR COLUMNS  
More than one style of column is typical of this porch type.

© 1998, Jenkins & Associates Architecture and Town Planning Ltd.

Section

## II. Building Elements

Drawing Name

# PORCHES

Drawing No.

# 3.11

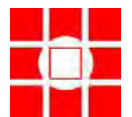

February 2007

## WINDOW PROPORTIONS

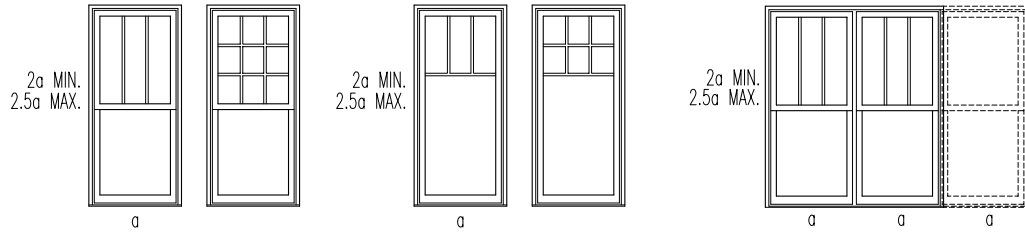

HUNG WINDOWS

CASEMENT WINDOWS

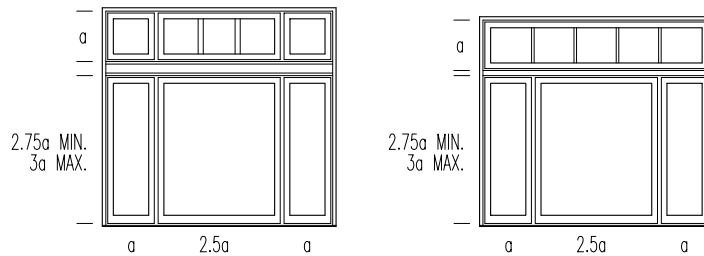

FEATURE WINDOW w/ TRANSOM

1. **MATERIALS: Windows**
  - shall be of wood; painted, stained, or clad.
  - some vinyl styles with prior approval.
2. Upper floor windows are to have a proportion of:  
2a : a **ONLY**.
3. Main floor windows are to have a proportion of:  
2a : a **TO** 2.4a : a
4. Transoms are permitted on main floor windows **ONLY**.
5. Transom windows are to have a square or vertically rectangular proportion.
6. Muntin bars are typically found in the upper sash of hung windows, or the upper third of casement windows.

© 1998, Jenkins & Associates Architecture and Town Planning Ltd.

Section

II. Building Elements

Drawing Name

**WINDOW TYPES**

Drawing No.

**3.12**



February 2007

## WINDOW SURROUND EXAMPLES

*On Stone/Masonry Buildings*

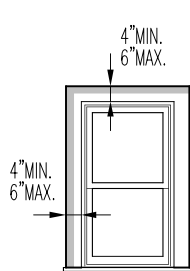

A.  
WOOD TRIM

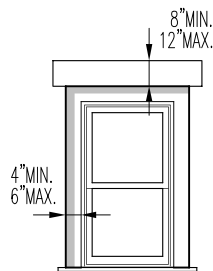

B.  
WOOD TRIM w/  
STONE CORNICE

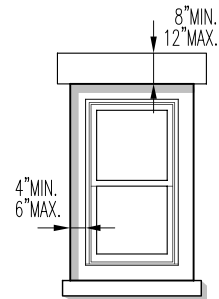

C.  
WOOD TRIM w/  
STONE  
CORNICE & STONE  
SILL

*On Wood/Stucco Buildings*

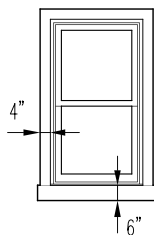

D.  
WOOD TRIM w/  
6\"/>

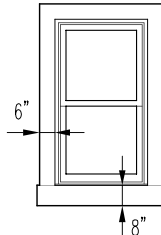

E.  
WOOD TRIM w/  
8\"/>

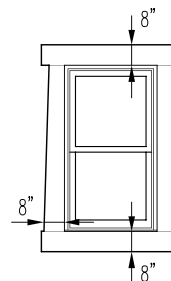

F.  
TAPERED TRIM w/  
SILL & CORNICE

1. MATERIALS: Surrounds
  - shall be of wood; painted or stained.
  - rough or smooth sawn timber.
  - see Materials Code for approved alternatives for wood.
2. Shutters are not permitted in this style.

© 1998, Jenkins & Associates Architecture and Town Planning Ltd.

Section

II. Building Elements

Drawing Name

WINDOW SURROUNDS

Drawing No.

3.13



February 2007



## DOOR TYPES

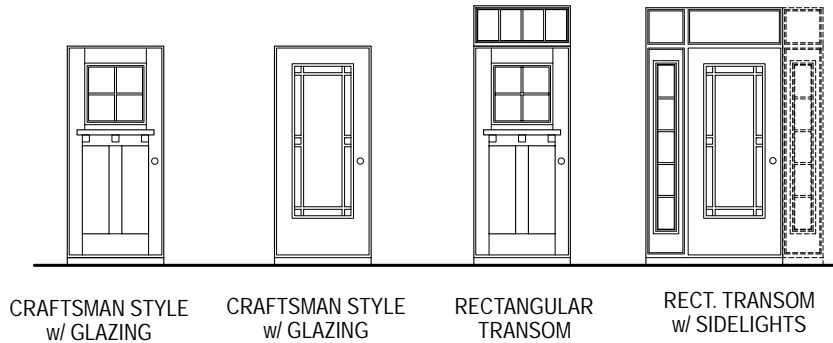

1. **MATERIALS: Doors**
  - shall be of wood; painted, stained, or clad.
  - insulated doors.
2. **MATERIALS: Surrounds**
  - shall be of wood; painted or stained.
  - rough or smooth sawn timber.
  - Smart Trim.
  - approved pre-manufactured cast/ mouldings.
  - vinyl or aluminum trim is not permitted.

## TRADITIONAL DOOR SURROUND EXAMPLES

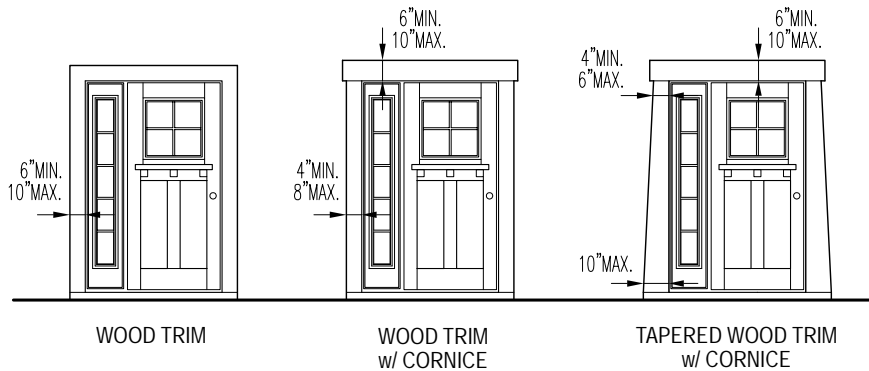

3. Door panel configurations may vary from those shown above.
4. Single sidelight, single sidelight with transom, are permitted on asymmetrically organized elevations ONLY.
5. Double sidelights, double sidelights with transom, are permitted on symmetrically organized elevations ONLY.
6. All surround styles may apply to all door and transom configurations.

© 1998, Jenkins & Associates Architecture and Town Planning Ltd.

Section

II. Building Elements

Drawing Name

DOORS & SURROUNDS

Drawing No.

3.14



February 2007

## TRADITIONAL EXAMPLES

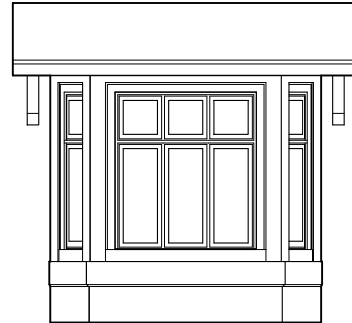
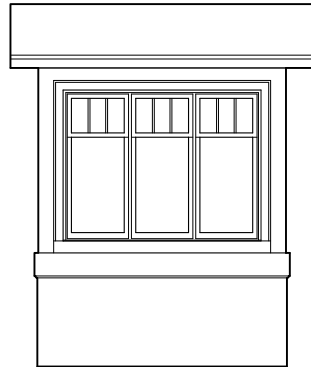

1. MATERIALS: Roofs  
- shall be the same as indicated in ROOFS.
2. MATERIALS: Base  
- shall be the same as the main body of the house.
3. MATERIALS: Body  
- the main body of the bay shall be panelled wood, Crezone panels, smooth or sprayed stucco, wood shingles, or horizontal bevelled wood siding.
4. Cantilevered bays are not permitted.
5. Single storey bays are common in this style.
6. The wall between the end bay and the nearest window of the bay shall be 12" MIN.
7. The main roof overhang often provides the roof for a bay on a bungalow.

© 1998, Jenkins & Associates Architecture and Town Planning Ltd.

Section

## II. Building Elements

Drawing Name

# BAYS

Drawing No.

# 3.15



February 2007

## DORMER WINDOW PROPORTIONS

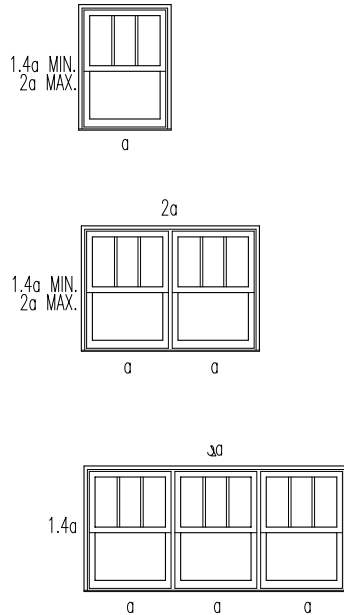

## TRADITIONAL DORMER EXAMPLES

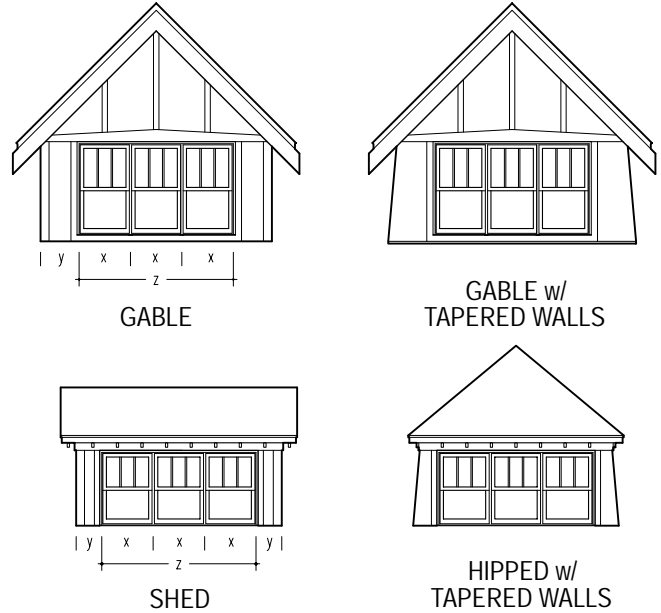

1. MATERIALS and NOTES as outlined for WINDOWS shall apply to all DORMERS.
2. MATERIALS: Front & Sides
  - horizontal bevelled wood siding
  - panelled exterior plywood.
  - decorative wood shingles.
  - wood shingles.
  - stucco with timber detailing.
3. SLOPE:
  - GABLED / HIPPED: the roof slope shall be the same as the MAIN ROOF.
  - SHED: 4:12 MIN. - 10:12 MAX.
4. The eaves shall overhang 12" MIN. - 24" MAX.
5. The fascia board shall be 6" MIN. - 12" MAX.
6. Fascia boards shall end as an exposed rafter end.
7. Exposed rafter ends are encouraged.
8. SHED dormers are to have ganged windows ONLY.
9. Ganged windows are encouraged on GABLED / HIPPED dormers.
10. Gable end detailing in dormers shall conform to GABLE ENDS.

© 1998, Jenkins & Associates Architecture and Town Planning Ltd.

Section

II. Building Elements

Drawing Name

**DORMERS**

Drawing No.

**3.16**



February 2007

## TRADITIONAL COLUMN EXAMPLES

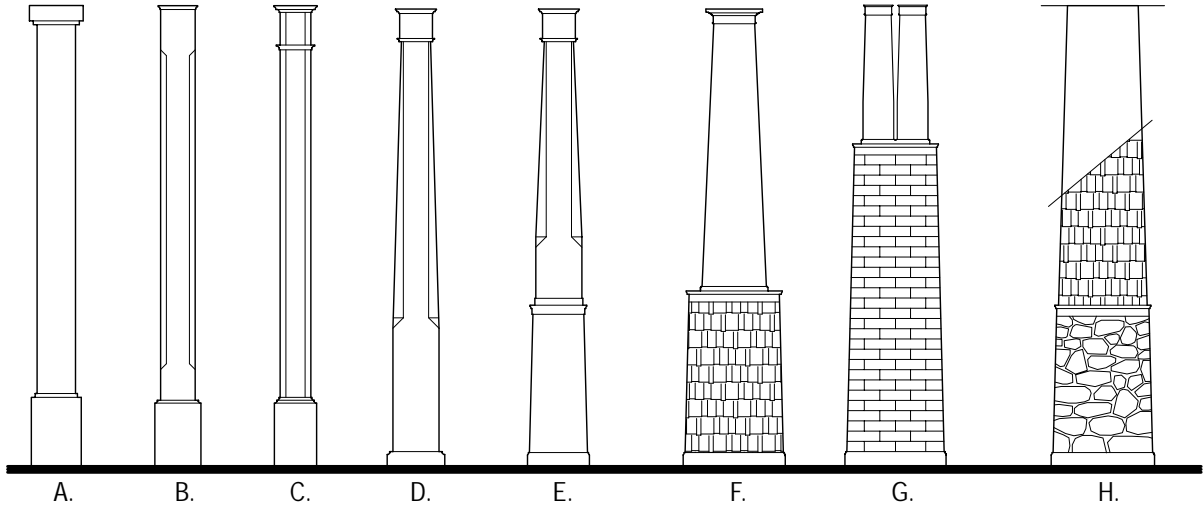

A. BOX  
 B. CHAMFERED BOX  
 C. SQUARE (CHAMFERED)  
 D. TAPERED BOX

E. TAPERED BOX on PLINTH  
 F. BROAD TAPERED SQ. on PLINTH  
 G. DBL. BROAD TAPERED SQ. on HIGH PEDESTAL  
 H. STONE / CEDAR SHINGLE COLUMN

1. MATERIALS: Columns
  - wood; painted.
  - pre-formed glass fibre casts will be permitted with prior approval only.
2. MATERIALS: Plinths & Balustrade Walls
  - wood; painted.
  - horizontal bevelled wood siding.
  - panelled exterior plywood.
  - wood shingles.
  - stucco with timber detailing.
  - stone.
  - vinyl siding is not permitted.
3. Aluminum columns or plinths are NOT encouraged.
4. Wood columns are to be 10" MIN. wide.
5. Stone columns shall be 18" MIN wide.
6. Plinths are to be 18" MIN. in depth, and square in plan.
7. All column types may be double when either freestanding or on a plinth.

© 1998, Jenkins & Associates Architecture and Town Planning Ltd.

Section

III. Details

Drawing Name

COLUMNS

Drawing No.

3.17

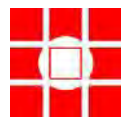

February 2007

## TRADITIONAL BALUSTRADE EXAMPLES

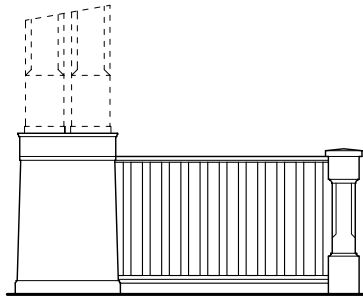

A.

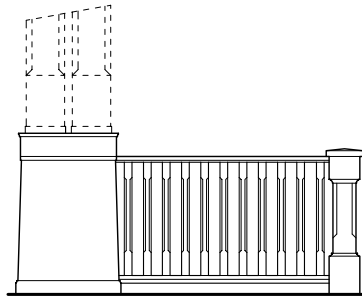

B.

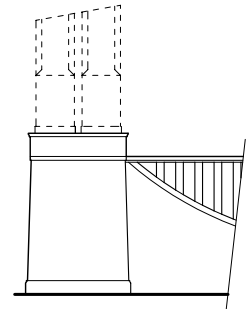

C.

- A. 2x2 SQUARE balustrade.
- B. 2x2 CHAMFERED square balustrade.
- C. COMPOSITE balustrade wall.
- D. CONTINUOUS stone column and plinth with balustrade wall.
- E. CONTINUOUS cedar shingle column and plinth with balustrade wall.

1. MATERIALS: Wood top and bottom rails with wood balusters, painted or stained.

2. MATERIALS: Plinths & Balustrade Walls

- wood; painted.
- horizontal bevelled wood siding.
- wood fibre siding.
- fibre cement siding.
- panelled exterior plywood.
- wood shingles.
- stucco with timber detailing.
- stone.
- vinyl siding is not permitted.

3. Balustrade walls may be clad with either the same or different materials than the columns or plinths.

4. Wood balusters shall be 2" x 2" MIN.

5. Top and bottom rails shall be 2" x 4" MIN.

6. Balustrade walls shall be 6" MIN. in depth.

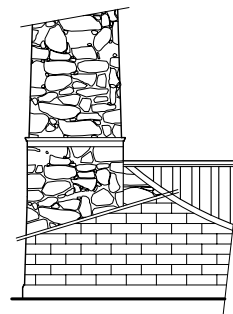

C.

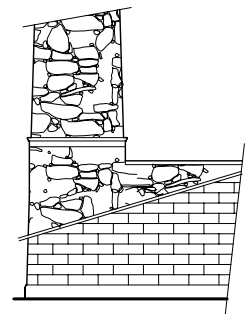

D.

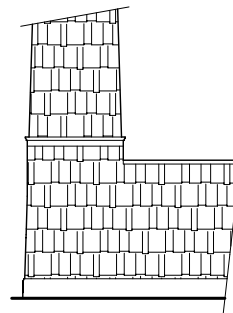

E.

© 1998, Jenkins & Associates Architecture and Town Planning Ltd.

Section

III. Details

Drawing Name

**BALUSTRADES**

Drawing No.

**3.18**



February 2007

## TRADITIONAL EXAMPLES

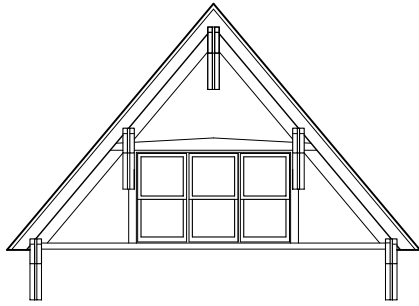

A. TRIANGULAR KNEE BRACES or EXPOSED BEAM ENDS

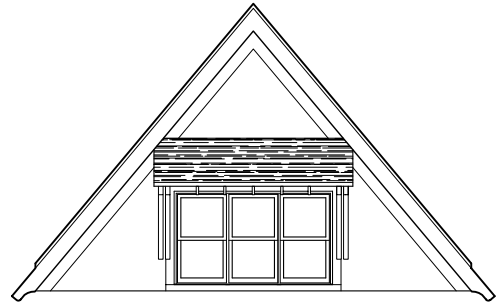

D. PENT ROOF on TRIANGULAR KNEE BRACES

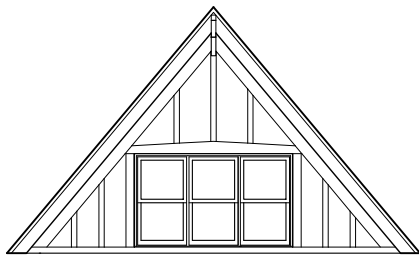

B. SMOOTH STUCCO and TIMBER PATTERNING

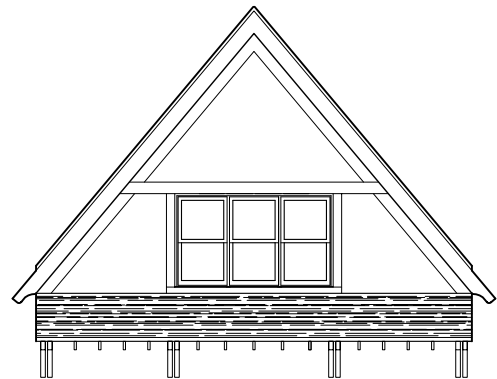

E. PENT ROOF on KNEE BRACES BELOW GABLE END

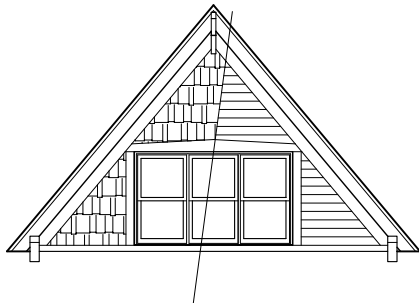

C. WOOD SHINGLES or HORIZONTAL WOOD SIDING

### 1. MATERIALS:

- horizontal bevelled wood siding.
- wood fibre siding.
- fibre cement siding.
- panelled exterior plywood.
- decorative wood shingles.
- wood shingles.
- stucco with timber detailing.

### 2. Roof and fascia details shall conform to ROOFS.

3. Windows in gangs of two or more will ONLY be permitted in GABLE ENDS; gangs of two are encouraged.

4. Braces and/or exposed rafters are typical for all gable end variations.

5. Gable ends are to use a different exterior cladding than the main body of the house.

6. Where the main body is clad in stucco, half timbering is sufficient to separate the gable from the main wall.

© 1998, Jenkins & Associates Architecture and Town Planning Ltd.

Section

III. Details

Drawing Name

GABLE ENDS

Drawing No.

3.19

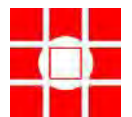

February 2007

# THE DIOCESE PROPERTY

## *Craftsman Style Materials & Colour Codes*

The intent of the 'Craftsman Style' Materials and Colour Specifications are to assist the builders in identifying materials and colours suitable for Craftsman Style buildings on the Diocese Property. The approved materials and colours are the result of research of Craftsman Style houses particular to the City of Regina. It is the combination of architectural style, and the appropriate materials and colours to the Craftsman Style that results in a historically accurate representation for the neighbourhood of the Diocese Property.

Craftsman Style buildings typically are smooth stucco, siding, or brick. The main body of the structure is usually an earth-tone colour with white windows and trim. Extended eaves, exposed rafters and extended fascia ends are features of Craftsman Style buildings. Craftsman buildings usually have front porches. A building base is almost always present in the Craftsman Style. Base materials include cedar shingles, stone, brick, or bevelled siding. When using brick, rumbled brick with a ½" slightly tooled mortar joint are most common.

Using the Diocese Property Codes:

- The Diocese Property Architectural Codes define approved materials for Craftsman Style buildings and where the materials may be used.
- The Materials Matrix defines the type and manufacturer of approved materials for Craftsman Style buildings.
- The Colour Matrix defines approved paint and stain colours for Craftsman Style buildings.
- The Materials & Colours Specifications printed in colour, are intended to act as a visual guide to the matrices noted above.

It is essential to use all Code references **concurrently** to provide a comprehensive understanding of the style. This is the intent of the Diocese Property Codes.

**ROOFING:**

● APPROVED ○ NOT APPROVED

DESCRIPTION	MANUFACTURER	CODE/MATERIAL	SIZE	WARRANTY	COLOUR	COMMENTS
ASPHALT SHINGLES	BP	ECLIPSE	N/A	LIFETIME	TWILIGHT GREY	
					STONEWOOD	
					WEATHERED ROCK	
					SHADOW BLACK	
					AUTUMN BROWN	
	IKO INDUSTRIES LTD.			30 YEAR	HARVARD SLATE	
		CHATEAU	N/A		WEATHERWOOD	
					DUAL BLACK	
					FOREST GREEN	
					TWILIGHT GREY	
FIBREGLASS SHINGLES	BP	HARMONY	N/A	30 YEAR	STONEWOOD	
					WEATHERED ROCK	
					SHADOW BLACK	
					AUTUMN BROWN	
	IKO INDUSTRIES LTD.	CAMBRIDGE	N/A	25 YEAR	HARVARD SLATE ULTRA	
					WEATHERWOOD ULTRA	
					DUAL BLACK ULTRA	
					FOREST GREEN ULTRA	
	TIMBERLINE	TIMBERLINE 35	N/A	35 YEAR	CHARCOAL BLEND	
					MISSION BROWN BLEND	
					PEWTER GRAY BLEND	
	ELK PREMIUM ROOFING	PRESTIQUE	N/A	30 YEAR	ANTIQUUE SLATE	
					WEATHERWOOD	
					SABLEWOOD	
					FOREST GREEN	
CONCRETE TILE	UNICRETE PRODUCTS LTD.	3A (SLATE - STANDARD PROFILE)	N/A	N/A	NEW BARK 0342	PERMITTED ON BUILDINGS WITH MIN. 50 FT. FRONTAGE
CONCRETE TILE	UNICRETE PRODUCTS LTD.	3A (SLATE - STANDARD PROFILE)	N/A	N/A	PARAMOUNT MOSS 0354	
CEMBRIT SLATE	UNICRETE PRODUCTS LTD.	DIAGONAL SLATE	400 X 400mm	N/A	BLACK	
CEMBRIT SLATE	UNICRETE PRODUCTS LTD.	DIAGONAL SLATE	600 X 600mm	N/A	BLACK	
NATURAL SLATE	UNIVERSAL SLATE INT.	SEMI-GAUGED	30 X 15cm	N/A	SUBMIT FOR APPROVAL	
NATURAL SLATE	UNIVERSAL SLATE INT.	SEMI-GAUGED	30 X 20cm	N/A	SUBMIT FOR APPROVAL	
NATURAL COPPER	SUBMIT FOR APPROVAL	N/A	N/A	N/A	N/A	
NATURAL ZINC	SUBMIT FOR APPROVAL	N/A	N/A	N/A	N/A	
CEDAR SHINGLES	SUBMIT FOR APPROVAL	N/A	N/A	N/A	REFER TO COLOR SCHEDULE	

● APPROVED ○ NOT APPROVED

**DIOCESSE PROPERTY ARCHITECTURAL GUIDELINES**

**MATERIALS & COLOURS MATRIX**

**CRAFTSMAN STYLE**

**M1**

**FEBRUARY 2007**

The Owner reserves the right to adjust the guidelines as necessary. All building plans and elevations must be submitted to the Site Architect for conformity to all standards. The drawing is not to be scaled. This drawing is to serve as a guideline ONLY.

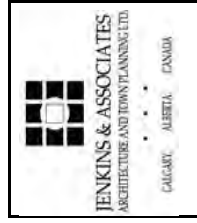



**WALL CLADDING:**

● APPROVED ○ NOT APPROVED

DESCRIPTION	MANUFACTURER	CODE/MATERIAL	COLOUR	CRAFTSMAN	COMMENTS
WOOD FIBRE SIDING	CANEXEL	- 6" CEDR VUE	WHITE	●	
			ALMOND	●	
			SAND	●	
			COUNTRY RED	●	
			ACADIA	●	
			SIERRA	●	
			MIST GREY	●	
			PINE GREEN	●	
			SCOTIA BLUE	●	
	SMARTSYSTEM		REFER TO COLOUR SCHEDULE	●	
		SMARTLAP	REFINISHING THROUGH		
			UNICRETE OR BARDON INDUSTRIES		
STUCCO	IMASCO MINERALS			●	NOTE: SMOOTH OR SAND FINISH ONLY
		PREMIX 1000 - SMOOTH OR SPRAYED SANDS - SMOOTH FINISH	LIGHT IVORY 6-53	○	
		ACRYLIC - SMOOTH FINISH	DARK IVORY 1-53	●	
			CANYON BRUSH 136 (1-6)	●	
			DARK HARVEST GOLD 1-46	●	
			LIGHT MOUNTAIN MIST 6-131	●	
			DARK MOUNTAIN MIST 1-131	○	
			DARK VENETIAN YELLOW 1-855	●	
			SLATE 820 (1-6)	●	
			DARK FRENCH GREY	●	
			LIGHT SUEDE 6-830	●	
			MEDIUM SUEDE 3-830	●	
			DARK SUEDE 6-830	●	
			REFER TO COLOUR SCHEDULE	●	
STUCCO	RYNOTEK	SMOOTH SUBSTRATE	REFER TO COLOUR SCHEDULE	●	
ACRYLIC STUCCO	ACRYLIC STUCCO	SMOOTH FINISH ACRYLIC	REFER TO COLOUR SCHEDULE	●	
HORIZ. BEVELLED WOOD SIDING	SUBMIT FOR APPROVAL	N/A	REFER TO COLOUR SCHEDULE	●	
WOOD SHINGLES	SUBMIT FOR APPROVAL	N/A	REFER TO COLOUR SCHEDULE	●	
HORIZ. BOARD & BATTEN	SUBMIT FOR APPROVAL	N/A	REFER TO COLOUR SCHEDULE	○	

DIOCESE PROPERTY ARCHITECTURAL GUIDELINES

MATERIALS & COLOURS MATRIX

CRAFTSMAN STYLE

M2

FEBRUARY 2007

The Owner reserves the right to adjust the guidelines as necessary.

These guidelines are intended to be used in conjunction with the Alberta Fair Access to Information Act. These guidelines are to be adhered to in addition to requirements of the Master Site Plan.

These guidelines are the intellectual property of JENKINS & ASSOCIATES ARCHITECTURE and TOWNPLANNING LTD. and may be reproduced only with the permission of the Architect in which case the reproduction must bear the name of the Architect.

This drawing is not to be scaled. This drawing is to be used as a guideline ONLY.

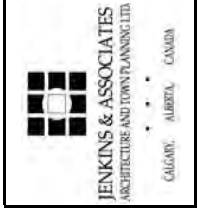

**WALL CLADDING:**

● APPROVED ○ NOT APPROVED

DESCRIPTION	MANUFACTURER	CODE/MATERIAL	SIZE	COLOUR	CRAFTSMAN	COMMENTS
HORIZONTAL	MITTEN VINYL INC.	OREGON PRIDE	D4.5 HORIZ.	FROST	○	
VINYL SIDING				CLAY	○	
				BONE WHITE	○	
				ASH	○	
				SANDALWOOD	○	
				BROWNSTONE	○	
				LITE MAPLE	○	
				RICHMOND RED	○	
		SENTRY A.C.T.	D4" HORIZ.	GRENADIER GREEN	○	
				KHAKI BROWN	○	
				HERITAGE	○	
				ANNAPOLIS BLUE	○	
				ACADEMY GREY	○	
				SNOW WHITE	○	
		CONCORD	D4 / T3	CANYON CLAY	○	
				LINEN	○	
				WICKER	○	
				ALMOND	○	
				ANTIQUÉ IVORY	○	
				MAIZE	○	
				PEBBLE	○	
				SAGE	○	
		SEQUOIA SELECT - PREMIUM	D4	AUTUMN RED	○	
				WALNUT	○	
				FLANNEL	○	
				COLONIAL	○	
				ARCADIAN	○	
				BROWNSTONE	○	
				WHITE	○	
		ROYAL WOODLAND	DOUBLE 4 1/2	CLAY	○	
			TRADITIONAL	LINEN	○	
				SAND	○	
				BEIGE	○	
				WHITE	○	
		ARCHITECTURAL SERIES	DOUBLE 4 1/2	CLAY	○	
			TRIPLE 3 (T3D)	LINEN	○	
				WICKER	○	
				SAND	○	



**DIOCESE  
PROPERTY  
ARCHITECTURAL  
GUIDELINES**

**MATERIALS &  
COLOURS  
MATRIX**

**CRAFTSMAN  
STYLE**

M3

**FEBRUARY 2007**

The owner reserves the right to adjust the guidelines as necessary.  
All building plans and elevations must be submitted to the site architect for conformity with all standards. These guidelines are intended to provide a minimum level of requirements of the Master Site Plan.  
This drawing is the exclusive property of JENKINS & ASSOCIATES ARCHITECTURE AND TOWN PLANNING LTD. and may be reproduced only with the permission of the site architect. All other uses are prohibited. This drawing is not to be scaled. This drawing is to serve as a guideline ONLY.

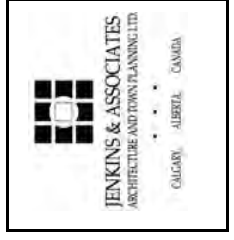

**WALL CLADDING:**      ● APPROVED      ○ NOT APPROVED

DESCRIPTION	MANUFACTURER	CODE/MATERIAL	SIZE	COLOUR	COMMENTS
DECORATIVE VINYL SHINGLES FOR GABLES	NAILITE INTERNATIONAL	HAND-SPLIT SHAKE		COTTAGE WHITE	<input type="radio"/>
				BIRCHWOOD	<input type="radio"/>
				DRIFTWOOD GRAY	<input type="radio"/>
				GRANITE GRAY	<input type="radio"/>
				POTTER'S CLAY	<input type="radio"/>
				WEATHERED WHITE	<input type="radio"/>
				TRADITIONAL CEDAR	<input type="radio"/>
				NATURAL CEDAR	<input type="radio"/>
FIBRE CEMENT SIDING	JAMES HARDIE	HARDPLANK	5" EXPOSURE SMOOTH OR CEDARMILL	ARCTIC WHITE	<input checked="" type="radio"/>
				NAVAJO WHITE	<input checked="" type="radio"/>
				MONTEREY GRAY	<input checked="" type="radio"/>
				COLONIAL GRAY	<input checked="" type="radio"/>
				KHAKI BROWN	<input checked="" type="radio"/>
				REDWOOD	<input checked="" type="radio"/>
				FRENCH VANILLA	<input checked="" type="radio"/>
				WHITE SAND	<input type="radio"/>
				SILVER MIST	<input type="radio"/>
				OUTBACK	<input type="radio"/>
				DUNE	<input type="radio"/>
				SATIN BEIGE	<input type="radio"/>
				JUNGLE PALM	<input type="radio"/>
				EXCALLIBER	<input type="radio"/>
				NAVAJO BEIGE	<input checked="" type="radio"/>
				MONTEREY TAUPE	<input checked="" type="radio"/>
				BOOTHBAY BLUE	<input checked="" type="radio"/>
				WOODSTOCK BROWN	<input checked="" type="radio"/>
				AUTUMN TAN	<input checked="" type="radio"/>
				SANDSTONE BEIGE	<input checked="" type="radio"/>
				HEATHERED MOSS	<input checked="" type="radio"/>
				TIMBER BARK	<input checked="" type="radio"/>
				MOUNTAIN SAGE	<input checked="" type="radio"/>
				COUNTRYLANE RED	<input checked="" type="radio"/>

**DIOCESE PROPERTY ARCHITECTURAL GUIDELINES**

**MATERIALS & COLOURS MATRIX**

**CRAFTSMAN STYLE**

**M4**

**FEBRUARY 2007**

The Owner reserves the right to adjust the guidelines as necessary. All building plans and elevations must be submitted to the City of Calgary for review and approval. These guidelines do not supersede the requirements of the Master Site Plan. This drawing is the intellectual property of JENKINS & ASSOCIATES ARCHITECTURE AND TOWN PLANNING LTD. and is for review and approval only. No other use of the material in this book can be made without the written permission of the author. The book can only be used for projects that bear the name of the Architect. This drawing is to serve as a guideline ONLY.





**BASE MATERIAL:**

● APPROVED ○ NOT APPROVED

DESCRIPTION	MANUFACTURER	CODE/MATERIAL	COLOUR	COMMENTS
REINFORCED CEMENTITIOUS PANEL	STONETILE (CANADA)	RUSTIC TILE	ANTIQUE WHITE	
			SANDSTONE	○
			ANTIQUE GREY	○
		HERITAGE STONE	ANTIQUE WHITE	○
			SANDSTONE	○
			ANTIQUE GREY	○
MANUFACTURED STONE	CULTURED STONE	RIVER ROCK	WHITEWATER	● NOTE: CULTURED & NATURAL STONE MAY BE
		SPLIT FACE	GRANITE	● USED FOR BASE AND FIREPLACE ONLY
		COBBLEFIELD	OHIO	○ FOR CRAFTSMAN STYLE HOMES
		COBBLEFIELD	GRAY	○
		COBBLEFIELD	SAN FRANCISCO	○
		LIMESTONE	BUCKEYE	○
		SOUTHERN LEDGESTONE	FOG	●
		COUNTRY LEDGESTONE	CHARDONNAY	●
		LIMESTONE	LAKE ERIE	○
		SOUTHERN LEDGESTONE	WALNUT	●
		SOUTHERN LEDGESTONE	CHARDONNAY	○
		SOUTHERN LEDGESTONE	BLACK RUNDLE	●
		COUNTRY LEDGESTONE	EUCALYPTUS	●
		SOUTHERN LEDGESTONE	BUCKS COUNTY	●
		SOUTHERN LEDGESTONE	RUSTIC	●
		SUBMIT FOR APPROVAL	SUBMIT FOR APPROVAL	●
		APALACHIAN FIELDSTONE	ANCHORAGE GRAY	●
		OLD WORLD LEDGE	RIO VERDE	●
		VIRGINIA LEDGE	STORM BROWN	●
		MOUNTAIN LEDGE	RUNDLE	●
		IDAHO DRYSTACK	SMOKEY GREY	●
		RIVER ROCK	GREY GRANITE	●
		QUICK STACK	CARMEL MOUNTAIN	●
	ELDORADO STONE	MOUNTAIN LEDGE	MESA VERDE	●
		MOUNTAIN LEDGE	DARK RUNDLE	●
		RUSTIC LEDGE	CASCADE	●
		LIMESTONE	YORK	○
		RIVER ROCK	RIO GRANDE	●
		RUNDLESTONE	BLACK	●
NATURAL STONE	I-XL		NATURAL 1" BLACK RUNDLE	●
			W/ KOOTENAY BROWN (90/10)	●
		SUBMIT FOR APPROVAL	SUBMIT FOR APPROVAL	●

CR  
A  
F  
T  
S  
M  
A  
N

**DIOCESE  
PROPERTY  
ARCHITECTURAL  
GUIDELINES**

**MATERIALS &  
COLOURS  
MATRIX**

**CRAFTSMAN  
STYLE**

**M6**

**FEBRUARY 2007**

The Owner reserves the right to adjust the guidelines as necessary. All building products to be submitted to the Site Architect for conformity to all standards. These Guidelines are to be adhered to in addition to requirements of the Master Site Plan. This drawing is the exclusive property of JENKINS & ASSOCIATES ARCHITECTURE AND TOWN PLANNING LTD. and may be reproduced only with the permission of the Architect in which case the reproduction must bear the name of the Architect. This drawing is not to be scaled. This drawing is to serve as a guideline ONLY.



**JENKINS & ASSOCIATES**  
ARCHITECTURE AND TOWN PLANNING LTD.

CALGARY • ALBERTA • CANADA

**WINDOWS AND DOORS:**

● APPROVED ○ NOT APPROVED

DESCRIPTION	MANUFACTURER	CODE / MATERIAL	SIZE	COLOUR	CRAFTSMAN	COMMENTS
METAL CLAD UNITS	SUBMIT FOR APPROVAL	N/A	REFER TO ARCH. CODES	REFER TO COLOUR SCHEDULE	●	
	ALL WEATHER WINDOWS	N/A	REFER TO ARCH. CODES	WICKER	●	
				ARCHITECTURAL BROWN	○	
				CHOCOLATE BROWN	○	
	CWD	N/A		SANDLEWOOD	●	
				BRONZE METALLIC	○	
PVC UNITS	SUBMIT FOR APPROVAL	N/A	REFER TO ARCH. CODES	REFER TO COLOUR SCHEDULE	●	
	ALL WEATHER WINDOWS			WICKER	○	
	CWD			SANDLEWOOD	○	
WOOD UNITS	SUBMIT FOR APPROVAL	N/A	REFER TO ARCH. CODES	REFER TO COLOUR SCHEDULE	●	

**EXTERIOR DETAILING:**

● APPROVED ○ NOT APPROVED

DESCRIPTION	MANUFACTURER	CODE / MATERIAL	SIZE	COLOUR	CRAFTSMAN	COMMENTS
SHUTTERS	SUBMIT FOR APPROVAL	N/A	REFER TO ARCH. CODES	REFER TO COLOUR SCHEDULE	○	
TRIM	N/A	ROUGH OR SMOOTH SAWN WOOD*	REFER TO ARCH. CODES	REFER TO COLOUR SCHEDULE	●	
TRIM	SMARTSYSTEM / JAMES HARDIE	SMART TRIM / HARDIETRIM	REFER TO ARCH. CODES	REFER TO COLOUR SCHEDULE	●	
CORNICE, FRIEZE DETAILS, SILL, HEADER	SUBMIT FOR APPROVAL	WOOD, MOLDED POLY	REFER TO ARCH. CODE	REFER TO COLOUR SCHEDULE	●	
CORNICE, FRIEZE DETAILS, SILL, HEADER	STONETILE (CANADA) LTD.	REINFORCED CAST CONC. MOULDING	REFER TO ARCH. CODE	SUBMIT FOR APPROVAL	●	OR APPROVED EQUAL
FASCIA	SUBMIT FOR APPROVAL	WOOD, ALUMINUM ONLY	REFER TO ARCH. CODE	REFER TO COLOUR SCHEDULE	●	
SOFFITS	SUBMIT FOR APPROVAL	WOOD, ALUMINUM, OR VINYL	N/A	REFER TO COLOUR SCHEDULE	●	
FASCIA / SOFFITS	GENTEK	ALUMINUM		NUTMEG	○	
				SLATE	○	
				SABLE	○	
				BLACK	○	
				ROYAL LINEN #924	●	MATCHES OC-120 (BENJAMIN MOORE)
	MONARCH SIDING CENTRE	ALUMINUM		ROYAL CLAY #913	●	MATCHES R-9993 (BENJAMIN MOORE)
				ROYAL BEIGE #902	●	MATCHES OC-120 (BENJAMIN MOORE)
	CAN-ALUM BUILDING PRODUCTS	ALUMINUM		REYNOLDS ROYAL LINEN #924	●	MATCHES OC-120 (BENJAMIN MOORE)
				REYNOLDS ROYAL CLAY #913	●	MATCHES R-9993 (BENJAMIN MOORE)
				REYNOLDS IVORY #902	○	
CORNER BOARDS	N/A	WOOD, APPROVED VINYL	REFER TO ARCH. CODE	REFER TO COLOUR SCHEDULE	●	
EAVESTROUGHS AND DOWNSPOUTS	N/A	ALUMINUM	STANDARD RESIDENTIAL	MATCH TO TRIM COLOURS	●	
FENCING	SUBMIT FOR APPROVAL	WROUGHT IRON	REFER TO ARCH. CODES	BLACK ONLY	●	SUBMIT SHOP DRAWING
FENCING	SUBMIT FOR APPROVAL	WOOD	REFER TO ARCH. CODES	WHITE ONLY	●	

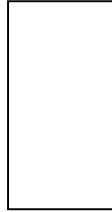

**DIOCSE  
PROPERTY  
ARCHITECTURAL  
GUIDELINES**

**MATERIALS &  
COLOURS  
MATRIX**

**CRAFTSMAN  
STYLE**

M7

**FEBRUARY 2007**

The Owner reserves the right to adjust the guidelines as necessary. Any modifications must be submitted to the Site Architect for conformity to all standards. These Guidelines are to be adhered to in addition to requirements of the Master Site Plan.  
This drawing is the exclusive property of JENKINS & ASSOCIATES ARCHITECTURE and TOWNPLANNING LTD. and may be reproduced only with the permission of the Architect in which case the reproduction must bear the name of the firm.  
This drawing is not to be scaled. This drawing is to serve as a guideline ONLY.

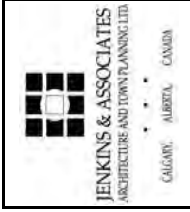

**COLOUR SCHEDULE:**

● APPROVED ○ NOT APPROVED

MANUFACTURER	COLOUR (OLD #)	CRAFTSMAN										COMMENTS			
		MAIN BODY OF HOUSE	TRIM	DOORS	WINDOWS	DOOR & WINDOW SURROUNDS	SHUTTERS	COLUMNS & BALUSTRADES	CORNICE & FRIEZE DETAILING	GABLE ENDS	SOFFITS AND FASCIA				
BENJAMIN MOORE	HC-26	○	○	○	○	○	○	○	○	○	○	○	○	○	
	HC-76	○	○	○	○	○	○	○	○	○	○	○	○	○	
	HC-79	○	○	○	○	○	○	○	○	○	○	○	○	○	
	HC-82	○	○	○	○	○	○	○	○	○	○	○	○	○	
	HC-85	○	○	○	○	○	○	○	○	○	○	○	○	○	
	HC-86	○	○	○	○	○	○	○	○	○	○	○	○	○	
	HC-88	○	○	○	○	○	○	○	○	○	○	○	○	○	
	HC-89	○	○	○	○	○	○	○	○	○	○	○	○	○	
	HC-95	○	○	○	○	○	○	○	○	○	○	○	○	○	
	HC-100	○	○	○	○	○	○	○	○	○	○	○	○	○	
	HC-101	○	○	○	○	○	○	○	○	○	○	○	○	○	
	HC-102	○	○	○	○	○	○	○	○	○	○	○	○	○	
	HC-103	○	○	○	○	○	○	○	○	○	○	○	○	○	
	HC-106	○	○	○	○	○	○	○	○	○	○	○	○	○	
	CC-480	○	●	○	○	○	○	○	○	○	○	○	○	○	To match CWD's Sandlewood windows
	2109-10	○	○	○	○	○	○	○	○	○	○	○	○	○	
	2114-10	○	○	○	○	○	○	○	○	○	○	○	○	○	
	2115-10	○	○	○	○	○	○	○	○	○	○	○	○	○	
	2128-10	○	○	○	○	○	○	○	○	○	○	○	○	○	
	2134-10	○	○	○	○	○	○	○	○	○	○	○	○	○	
	2134-20	○	○	○	○	○	○	○	○	○	○	○	○	○	
	2139-20	○	○	○	○	○	○	○	○	○	○	○	○	○	
	2089-20 (034)	○	○	○	○	○	○	○	○	○	○	○	○	○	
	2089-10 (035)	○	○	○	○	○	○	○	○	○	○	○	○	○	
	2085-10 (042)	○	○	○	○	○	○	○	○	○	○	○	○	○	
	R-9929 (063)	○	○	○	○	○	○	○	○	○	○	○	○	○	
	CC-180 (170)	○	○	○	○	○	○	○	○	○	○	○	○	○	
	HC-12 (171)	○	○	○	○	○	○	○	○	○	○	○	○	○	
	2154-40 (194)	○	○	○	○	○	○	○	○	○	○	○	○	○	
	R-9936 (195)	○	○	○	○	○	○	○	○	○	○	○	○	○	
	2148-10 (231)	○	○	○	○	○	○	○	○	○	○	○	○	○	
	2148-20 (251)	○	○	○	○	○	○	○	○	○	○	○	○	○	
	HC-22 (273)	○	○	○	○	○	○	○	○	○	○	○	○	○	
	HC-122 (441)	○	○	○	○	○	○	○	○	○	○	○	○	○	
	CC-630 (469)	○	○	○	○	○	○	○	○	○	○	○	○	○	
	2144-10 (490)	○	○	○	○	○	○	○	○	○	○	○	○	○	
	2144-20 (497)	○	○	○	○	○	○	○	○	○	○	○	○	○	
	R-9993	○	○	○	○	○	○	○	○	○	○	○	○	○	To match All Weather Windows Wicker windows

**DIOCESE  
PROPERTY  
ARCHITECTURAL  
GUIDELINES**

**COLOURS  
MATRIX**

**CRAFTSMAN  
STYLE**

M8

FEBRUARY 2007

The owner reserves the right to adjust the guidelines. All building plans and elevations must be submitted to the site architect for conformity as an illustration of the requirements of the Master Style Plan. This drawing is the exclusive property of JENKINS & ASSOCIATES ARCHITECTURE AND TOWN PLANNING LTD. and may be reproduced only with the permission of the Architect in which case the reproduction must serve as a guideline ONLY.



**COLOUR SCHEDULE:**

● APPROVED ○ NOT APPROVED

MANUFACTURER	COLOUR (OLD #)	CRAFTSMAN										COMMENTS			
		MAIN BODY OF HOUSE	TRIM	DOORS	WINDOWS	DOOR & WINDOW SURROUNDS	SHUTTERS	COLUMNS & BALUSTRADES	CORNICE & FRIEZE DETAILING	GABLE ENDS	SOFFITS AND FASCIA				
BENJAMIN MOORE	2142-30 (511)	●	○	●	●	○	○	○	○	○	○	○	○	○	
	2143-10 (517)	●	○	●	●	○	○	○	○	○	○	○	○	○	
	2143-20 (525)	●	○	●	●	○	○	○	○	○	○	○	○	○	
	HC-135 (644)	●	○	●	●	○	○	○	○	○	○	○	○	○	
	OC-120 (926)	●	○	●	●	○	○	○	○	○	○	○	○	○	
	OC-132 (927)	●	○	●	●	○	○	○	○	○	○	○	○	○	
	OC-108 (931)	●	○	●	●	○	○	○	○	○	○	○	○	○	
	OC-109 (932)	●	○	●	●	○	○	○	○	○	○	○	○	○	
	OC-130 (967)	●	○	●	●	○	○	○	○	○	○	○	○	○	
	HC-41 (1099)	●	○	●	●	○	○	○	○	○	○	○	○	○	
	CC-420 (1104)	●	○	●	●	○	○	○	○	○	○	○	○	○	
	2161-30 (1113)	●	○	●	●	○	○	○	○	○	○	○	○	○	
	2163-10 (1134)	●	○	●	●	○	○	○	○	○	○	○	○	○	
	HC-68 (1238)	○	○	○	○	○	○	○	○	○	○	○	○	○	
	2172-30 (1301)	●	○	●	●	○	○	○	○	○	○	○	○	○	
HC-108 (1487)	●	○	●	●	○	○	○	○	○	○	○	○	○		
HC-107 (1488)	●	○	●	●	○	○	○	○	○	○	○	○	○		
HC-100 (1489)	●	○	●	●	○	○	○	○	○	○	○	○	○		
2142-30 (1526)	●	○	●	●	○	○	○	○	○	○	○	○	○		
2137-30 (1540)	●	○	●	●	○	○	○	○	○	○	○	○	○		
R-9984 (1582)	●	○	●	●	○	○	○	○	○	○	○	○	○		
WHITE	●	○	●	●	○	○	○	○	○	○	○	○	○		
BLACK	○	○	○	○	○	○	○	○	○	○	○	○	○		
BEHR STAINS	704	●	○	●	●	○	○	○	○	○	○	○	○		
	708	●	○	●	●	○	○	○	○	○	○	○	○		
	710	●	○	●	●	○	○	○	○	○	○	○	○		
	712	●	○	●	●	○	○	○	○	○	○	○	○		
	720	●	○	●	●	○	○	○	○	○	○	○	○		
	723	●	○	●	●	○	○	○	○	○	○	○	○		
	724	●	○	●	●	○	○	○	○	○	○	○	○		
	725	●	○	●	●	○	○	○	○	○	○	○	○		
	728	●	○	●	●	○	○	○	○	○	○	○	○		
BEHR	CANDY APPLE	○	○	○	○	○	○	○	○	○	○	○	○		
HI-GLOSS ENAMEL	TEAL	○	○	○	○	○	○	○	○	○	○	○	○		
	BLACK BLACK	○	○	○	○	○	○	○	○	○	○	○	○		
COLOR YOUR	5519	○	○	○	○	○	○	○	○	○	○	○	○		
	5719	○	○	○	○	○	○	○	○	○	○	○	○		
WORLD	6519	○	○	○	○	○	○	○	○	○	○	○	○		

DIOCESE  
PROPERTY  
ARCHITECTURAL  
GUIDELINES

COLOURS  
MATRIX

CRAFTSMAN  
STYLE

M9

FEBRUARY 2007

The Owner reserves the right to adjust the guidelines  
All building plans and elevations must be submitted to  
the Architect for conformity to all standards,  
regulations and requirements of the Municipality of  
Edmonton.  
This drawing is the exclusive property of JENKINS &  
ASSOCIATES ARCHITECTURE AND TOWN PLANNING LTD.  
and may be reproduced only with the permission of  
the Architect in which case the reproduction must  
refer to this drawing as a guideline ONLY.  
This drawing is not to be scaled. This drawing is to  
serve as a guideline ONLY.





DIOCESE  
PROPERTY



ARCHITECTURAL  
CODES

4

TOWERS & PODIA



## MATERIALS & COLOURS

1. Refer to the Diocese Property Urban Design Codes for maximum podium heights and tower setback requirements.
2. The two to three-storey street focus of buildings within High Density Policy Areas is to be emphasized by providing a change in material and/or colour between the lower two or three storeys of the podium and the upper floors of the tower.
3. Visually “stronger” or heavier materials, such as stone and masonry, shall occur on the podium portion of the building. Visually “weaker” and lighter materials, such as metal and glass, should be used on the storeys above the podium level.
4. Darker coloured materials shall be used on the podium. Visually lighter colours shall be used on the storeys above the podium level.
5. MATERIALS: Podium  
- to be brick or stone.
6. MATERIALS: Tower  
- brick, prefinished metal panels, aluminum composite panels, glass/aluminum curtain wall systems, concrete or painted concrete.
7. Guardrails, cornices, or other similar horizontal features, are required at the top of the podium to accentuate the break between the two portions of the building.

© 1998, Jenkins & Associates Architecture and Town Planning Ltd.

Section

I. Building Form

Drawing Name

**STREET ELEVATION**

Drawing No.

**4.01**



February 2007

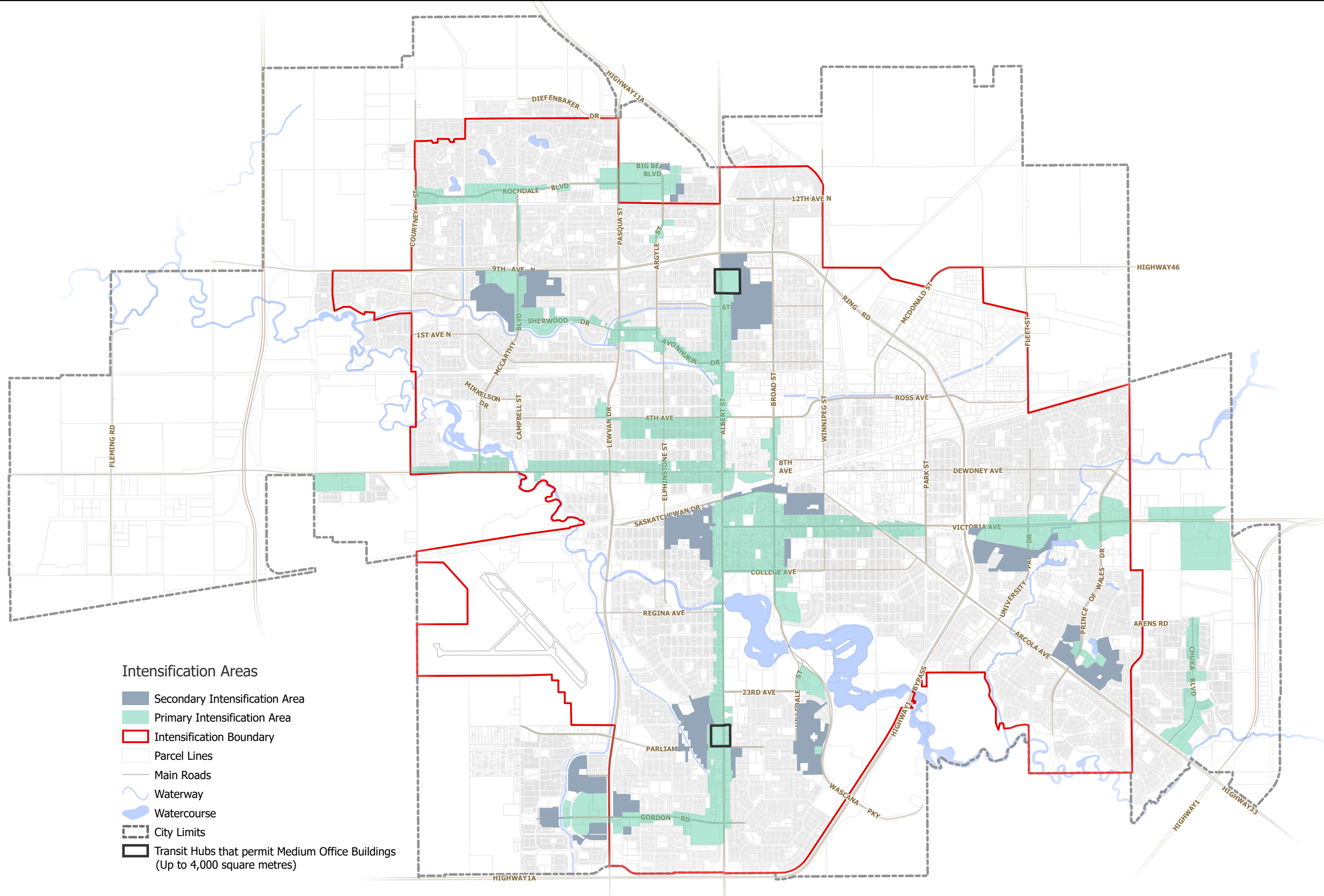

- Intensification Areas**
- Secondary Intensification Area
  - Primary Intensification Area
  - Intensification Boundary
  - Parcel Lines
  - Main Roads
  - Waterway
  - Watercourse
  - City Limits
  - Transit Hubs that permit Medium Office Buildings (Up to 4,000 square metres)

Figure 10.F1- Intensification Boundary and Area

0 0.5 1 2 Kilometers

